



Battery Range Summary

As the cost of electrical energy continues to rise and as energy consumption in applications such as data centers continues to grow, energy efficiency has become a topic of rising interest and concern for the Uninterruptible Power Supply (UPS) industry.

Furthermore, the increasing awareness of the impact of energy consumption on the environment has put additional pressure on decision makers to develop genuine power management strategies and to invest in eco-friendly initiatives. As a result, reducing costs and power usage through green initiatives has now become a critical target for many UPS players who have tried to respond by developing higher efficiency power management systems in order to reduce energy losses and ultimately operating costs.

EnerSys, the leader in stored energy solutions for industrial applications, is proud to be doing its part by developing the most effective and innovative products for a wide range of applications. The DataSafe® HX Valve Regulated Lead Acid (VRLA) battery can significantly contribute to helping customers achieve their business goals in mission-critical power back-up applications. Using advanced Thin Plate Pure Lead (TPPL) technology, combined with the selection of high grade, high purity materials enables EnerSys to deliver products with outstanding features and benefits.

Features and Benefits

- 530 and 600 Watts per Cell (15 min. rate to 1.67Vpc at 77°F (25°C))
- Specifically designed for high-rate discharge applications
- Excellent power density
- 10-12 year design life
- Low energy consumption
- UL94 V-0 flame retardant ABS plastic
- Low Total Cost of Ownership (TCO)

Construction

- High performance positive plates designed for long life and efficient recharge
- Negative plates provide perfect balance with the positive plates to ensure optimum recombination efficiency
- Separators in low resistance microporous glass fiber. The electrolyte is absorbed within this material, preventing acid leakage in case of accidental damage
- Electrolyte – high grade dilute sulphuric acid absorbed into separator material
- Containers and lids made of UL94 V-0 flame retardant ABS plastic
- High integrity, dual pillar seal design to ensure leak-free operation
- Self regulating pressure relief valves – prevent ingress of atmospheric oxygen

- A strong, detachable handle, designed to provide maximum flexibility during installation, is supplied with every pallet/case

Installation and Operation

- Batteries are designed for installation in cabinets or on stands, close to the point of use. A separate battery room is not necessary
- It is recommended that DataSafe® HX batteries are installed on their base
- Recommended float charge voltage: 2.29Vpc at 68°F (20°C) 2.27Vpc at 77°F (25°C)
- Up to two year shelf life
- Reduced maintenance: no water addition required
- Operating temperature range: -4°F (-20°C) to 113°F (45°C)

Standards

- Tested according to international standard IEC 60896-21 and compliant to defined requirements of IEC 60896-22
- Classified as "Long Life" (10/12 years) according to Eurobat guide 2015
- Approved to be shipped as non-spillable cargo in accordance with the requirements of IMDG (International Maritime code for Dangerous Goods) and ICAO (International Civil Aviation Organization)
- The management systems governing the manufacture of DataSafe® HX batteries are ISO 9001:2015 and ISO 14001:2004 certified

General Specifications

Battery Model	Nominal Ah		Watts/Cell	Nominal Dimensions						Typical Weight		Short Circuit Current (A)	Internal Resistance (mΩ)	Terminals	Electrolyte (1.300 SG)			
	Nominal Voltage (V)	8 hr rate to 1.75Vpc at 77°F (25°C)	15 min rate to 1.67Vpc at 77°F (25°C)	Length		Width		Overall* Height		lbs	kg				Volume	Weight		
				in	mm	in	mm	in	mm	lbs	kg	gal	L	lbs	kg			
12HX600T-FR	12	129	600	13.3	338	6.8	173	10.7	272	98.5	44.7	3800	3.30	M6 F	1.67	6.33	18.1	8.21
12HX530T-FR	12	126	530	13.3	338	6.8	173	10.7	272	89.9	40.8	3500	3.50	M6 F	1.90	7.19	20.5	9.30

12HX600T-FR Constant Power Discharge Data (Watts per Cell) @ 77°F (25°C)

Vpc	Standby Time (Minutes)						
	5	10	15	20	30	45	60
1.60	1136	780.8	607.5	497.3	369.4	271.0	214.8
1.63	1098	772.2	606.4	497.3	369.4	271.0	214.8
1.65	1070	764.8	604.3	497.3	369.4	271.0	214.8
1.67	1040	755.8	600.5	496.2	369.4	271.0	214.8
1.70	993.0	738.0	591.6	492.2	369.1	271.0	214.8
1.75	902.2	698.7	568.1	477.1	362.2	269.1	214.5

12HX530T-FR Constant Power Discharge Data (Watts per Cell) @ 77°F (25°C)

Vpc	Standby Time (Minutes)						
	5	10	15	20	30	45	60
1.60	930	688	536.4	439.5	326.8	240	190.4
1.63	909	680.2	535.4	439.5	326.8	240	190.4
1.65	893.2	673.7	533.8	439.5	326.8	240	190.4
1.67	876.2	665.8	530.4	438.5	326.8	240	190.4
1.70	848.1	650.4	522.2	435.2	326.5	240	190.4
1.75	794.3	616.8	501.6	422	320.6	238.3	190

Outline Drawing

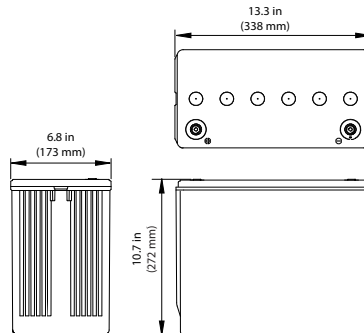

EnerSys World Headquarters
 2366 Bernville Road
 Reading, PA 19605, USA
 Tel: +1-610-208-1991 /
 +1-800-538-3627

EnerSys EMEA
 EH Europe GmbH
 Baarerstrasse 18
 6300 Zug, Switzerland

EnerSys APAC
 No. 85, Tuas Avenue 1
 Singapore 639518
 Tel: +65 6558 7333