



| an EnerSys company

LPS36

Line Power System

Technical Guide: 0120011-J0

Effective: 09/2019



Cordex HP LPS36/Compact -48Vdc to +/-190Vdc Line Power System

 **NOTE:**

Photographs contained in this manual are for illustrative purposes only. These photographs may not match your installation.

 **NOTE:**

Operator is cautioned to review the drawings and illustrations contained in this manual before proceeding. If there are questions regarding the safe operation of this powering system, contact Alpha Technologies or your nearest Alpha representative.

 **NOTE:**

Alpha shall not be held liable for any damage or injury involving its enclosures, power supplies, generators, batteries, or other hardware if used or operated in any manner or subject to any condition inconsistent with its intended purpose, or if installed or operated in an unapproved manner, or improperly maintained.

For technical support, contact Alpha Technologies:

Canada and USA: **1-888-462-7487**

International: **+1-604-436-5547**

Copyright

Copyright © 2019 Alpha Technologies Ltd. All rights reserved. Alpha is a registered trademark of Alpha Technologies.

No part of this documentation shall be reproduced, stored in a retrieval system, translated, transcribed, or transmitted in any form or by any means manual, electric, electronic, electromechanical, chemical, optical, or otherwise without prior explicit written permission from Alpha Technologies.

This document, the software it describes, and the information and know-how they contain constitute the proprietary, confidential and valuable trade secret information of Alpha Technologies, and may not be used for any unauthorized purpose, or disclosed to others without the prior written permission of Alpha Technologies.

The material contained in this document is for information only and is subject to change without notice. While reasonable efforts have been made in the preparation of this document to assure its accuracy, Alpha Technologies assumes no liability resulting from errors or omissions in this document, or from the use of the information contained herein. Alpha Technologies reserves the right to make changes in the product design without reservation and without notification to its users.

Table of Contents

1. Safety	7
1.1 Safety Symbols	7
1.2 General Warning and Cautions.....	7
1.3 Mechanical Safety.....	7
1.4 Electrical Safety	8
2. Product Overview	10
2.1 Product Part Numbers	11
2.2 Block Diagram—Three Shelves and a Fan Tray (19" and 23").....	12
3. Product Specifications	13
4. Features	15
4.1 Converter Modules.....	15
4.2 LPS36 System Features (19"/23").....	16
4.3 LPS Compact System Features (6").....	20
5. Site Evaluation and Pre-Installation	22
5.1 Pre-Installation Requirements.....	22
5.2 Packing Materials.....	23
6. LPS36 System Installation	24
6.1 General Instructions.....	24
6.2 Safety Precautions.....	24
6.3 Tools Required	25
6.4 Thermal Management.....	26
6.5 LPS36 Set Up: 19" and 23" Systems.....	29
6.6 LPS Compact Set Up: 6" Systems.....	34
6.7 Making Load Connections	42
6.8 System Startup with CXCI+ Controller.....	44
6.9 System Startup with the CXCI HP Controller	54

7. Maintenance and Troubleshooting	61
7.1 Troubleshooting Converter Status LEDs.....	61
7.2 Fan Filter Maintenance and Installation (19/23" only).....	63
7.3 Replacing the Fan Tray	65
7.4 Replacing a Converter (19"/23")	66
7.5 Replacing the Controller (19"/23" only).....	66
7.6 Replacing an Alarm Relay Module (19"/23" only)	67
7.7 Spare Parts	69
8. Warranty Statement and Service Information	70
8.1 Technical Support	70
8.2 Warranty Statement	70
8.3 Product Warranty	70
8.4 Battery Warranty	70
8.5 Warranty Claims.....	70
8.6 Service Information	70
9. Acronyms and Definitions	71
10. Certification	72

List of Figures

Figure 1 — LPS36 shelf (19" shown).....	10
Figure 2 — LPS36 Compact (6" shown), cable length not to scale	10
Figure 3 — LPS36 shelf (19" shown).....	16
Figure 4 — CXCI HP controller front panel.....	16
Figure 5 — Cordex CXCI+ controller front panel	17
Figure 6 — Shelf Connections	18
Figure 7 — Shelf Alarm LEDs	18
Figure 8 — Fan and Baffle Tray Rack, mounted (19" shown).....	19
Figure 9 — Shelf Connections	20
Figure 10 — DC input cable kit accessory (ordered separately, PN 8700870-001)	21
Figure 11 — Fan tray	21
Figure 12 — Natural Convection 19"/23" Systems	26
Figure 13 — Output Power Derating Curve	27
Figure 14 — Multi-shelf System Mounting	27
Figure 15 — LPS36 Compact Shelf with Fan Tray	28
Figure 16 — Minimum Air Flow.....	28
Figure 17 — Locations for protective earthing terminals for chassis ground (LPS36 side view)	30
Figure 18 — DC input connections (19")	30
Figure 19 — DC input wiring connections.....	31
Figure 20 — CAN and fan connections on the shelf interface panel (for reference only).....	31
Figure 21 — CAN OUT terminator	32
Figure 22 — CAN Bus cabling	32
Figure 23 — Fan tray connections.....	32
Figure 24 — Converter shelf alarm relays	33
Figure 25 — Fan Tray Alarm Relay.....	33
Figure 26 — Rack Mount Bracket Assembly (either side, based on installation).....	34
Figure 27 — Rack Mount (left side shown).....	35
Figure 28 — Rack Mount, Left side with Fan Tray	35
Figure 29 — Right Side Mount, with Fan Tray	36

Figure 30 — Rack Mount Left Side, LPS modules upside down	36
Figure 31 — Mounted Sideways (front of unit)	37
Figure 32 — Mounted Sideways (back of unit).....	37
Figure 33 — Locations for Chassis Ground (LPS36 Compact, side view)	39
Figure 34 — DC Input Connections	40
Figure 35 — DC Input Cable Kit Accessory	40
Figure 36 — PIN Assignment Table	41
Figure 37 — CAN Connection	41
Figure 38 — Connector Pinouts	42
Figure 39 — Live Graphical View	45
Figure 40 — Live Table View	45
Figure 41 — Channel Information for Position 6.....	46
Figure 42 — Grouping LPS Channels	47
Figure 43 — LPS Channel Custom Text.....	48
Figure 44 — LPS Alarm Highlighting	49
Figure 45 — Viewing LPS Alarms.....	49
Figure 46 — Configuring LPS Alarms.....	50
Figure 47 — Fan Tray Live Status	50
Figure 48 — Configuring a Custom Alarm	51
Figure 49 — Equation Editor for Configuring a Fan Fail Alarm.....	51
Figure 50 — Fan Fail Alarm	51
Figure 51 — Manage Editable Text Files	52
Figure 52 — Custom Name Change.....	52
Figure 53 — Line Power System Wizard	55
Figure 54 — Quick Reference: Configure a Line Power System.....	55

1. Safety

SAVE THESE INSTRUCTIONS: This manual contains important safety instructions that must be followed during the installation, servicing, and maintenance of the product. Keep it in a safe place. Review the drawings and illustrations contained in this manual before proceeding. If there are any questions regarding the safe installation or operation of this product, contact Alpha Technologies or the nearest Alpha representative.

1.1 Safety Symbols

To reduce the risk of injury or death, and to ensure the continued safe operation of this product, the following symbols have been placed throughout this manual. Where these symbols appear, use extra care and attention.



NOTE:

A NOTE provides additional information to help complete a specific task or procedure. Notes are designated with a checkmark, the word NOTE, and a rule beneath which the information appears



CAUTION!

CAUTION indicates safety information intended to PREVENT DAMAGE to material or equipment. Cautions are designated with a yellow warning triangle, the word CAUTION, and a rule beneath which the information appears.



WARNING!

WARNING presents safety information to PREVENT INJURY OR DEATH to personnel. Warnings are indicated by a shock hazard icon, the word WARNING, and a rule beneath which the information appears.



HOT!

The use of HOT presents safety information to PREVENT BURNS to the technician or user.

1.2 General Warning and Cautions



WARNING!

This system is designed to be installed in a restricted access location that is inaccessible to the general public.

1.3 Mechanical Safety



CAUTION!

Do not disassemble the product – call our qualified service centers for servicing. Incorrect reassembling may result in a risk of electrical shock or fire.

Do not operate the product if it has received a sharp blow, it has been dropped, or otherwise damaged in any way – return it to a qualified service center for repair.

1.4 Electrical Safety

WARNING!

The DC input to the modules (and the converter system) – though not dangerous in voltage – has a high short circuit current capacity that may cause severe burns and electrical arcing.

The DC output is a potentially dangerous voltage. Do not touch the output connections when under power. Ensure that power has been removed from the outputs before working on them.

Before working with any live battery or power system, follow these precautions:

- Remove all metallic jewelry, such as watches, rings, metal rimmed glasses, or necklaces.
- Wear safety glasses with side shields at all times during the installation.
- Use OSHA approved insulated hand tools. Do not rest tools on top of batteries.

NOTE:

The DC output is classified as an RFT-V circuit with a maximum rated power of 100W per channel. Paralleling of RFT-V circuits over multiple telecommunications wires for the purpose of delivering power in excess of 100VA to a single load circuit is not permitted. Refer to UL/CSA 60950-1 Section 6.2.1 for details.

RFT-V output circuit configuration – normal operation (permitted)

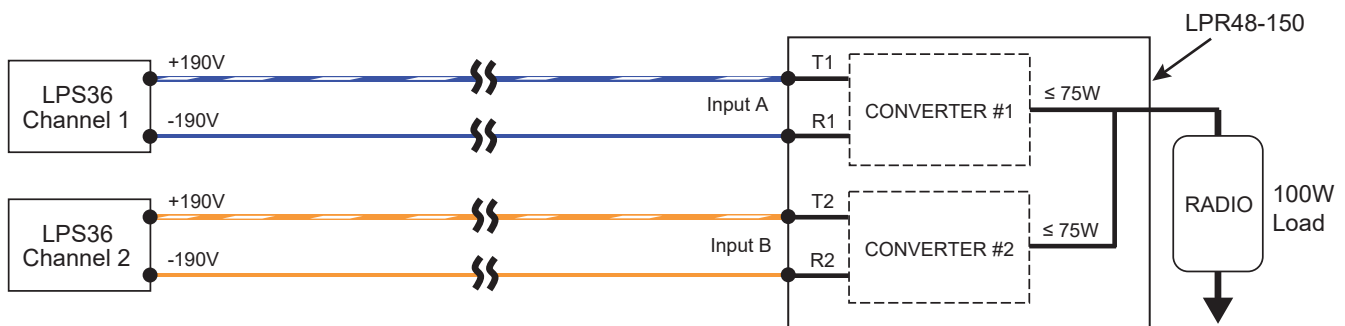

RFT-V output circuit configuration – bridged operation (not permitted)

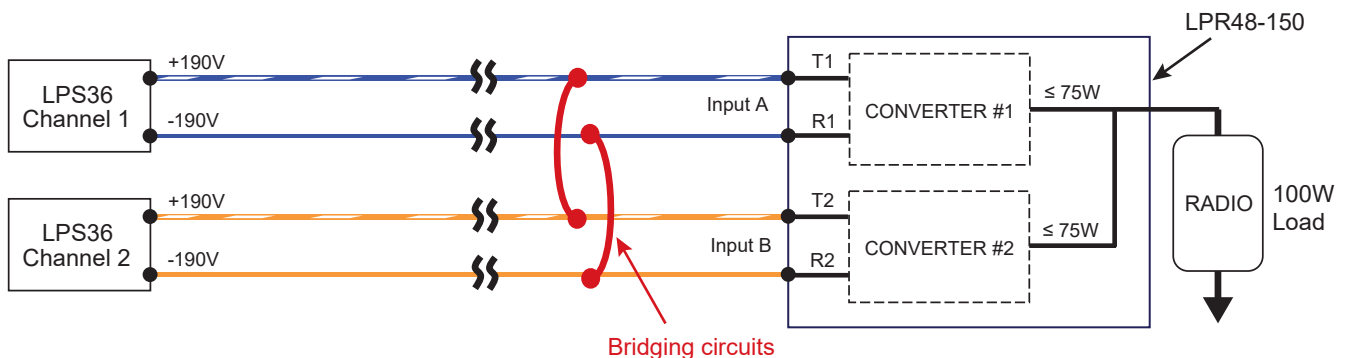

 **WARNING!**

Lethal voltages are present within the power system. Always assume that an electrical connection or conductor is energized. Check the circuit with a voltmeter with respect to the grounded portion of the enclosure (both AC and DC) before performing any installation or removal procedure.

- Do not work alone under hazardous conditions.
- A licensed electrician is required to install permanently wired equipment. Hazardous voltages are present at the input of power systems. Ensure that the utility power is disconnected and locked out before performing any installation or removal procedure.
- Ensure that no liquids or wet clothes come into contact with internal components.
- Hazardous electrically live parts inside this unit are energized from the batteries even when the AC input power is disconnected.
- The enclosure which contains the DC or AC power system along with customer installed radios must remain locked at all times, except when authorized service personnel are present.
- Always assume electrical connections or conductors are live. Turn off all circuit breakers and double-check with a voltmeter before performing installation or maintenance.
- Place a warning label on the utility panel to warn emergency personnel that a reserve battery source is present which will power the loads in a power outage condition or if the AC disconnect breaker is turned off.
- At high ambient temperature conditions, the internal temperature can be hot so use caution when touching the equipment.

2. Product Overview

The LPS36 is a modular DC to DC up-converter system designed for distributed power communications applications using +/- 190Vdc (RFT-V circuit) over existing copper network.

Using switched mode technology, the LPS36 quad output converter module provides outstanding efficiency in a compact design. Applications include powering sealed DSLAM's, Distribution Point Units (DPU) as well as Optical Network Terminals (ONT) in Fiber to the Home Networks (FTTH). Each LPS36 converter module contains four isolated DC-DC converters, up to 100 Watt maximum. Converter modules are ordered separately at time of ordering or later after the converter system has been installed. Blank plates can be ordered separately for empty slots.

- High efficiency >92% for increased operating expenses (OPEX) savings and reduced carbon footprint
- High temperature tolerance for installation in Central Office (CO) or harsh outside plant (OSP) cabinet environments
- Industry leading power density enabling up to 48 channels in a compact 2RU footprint
- High reliability convection-cooled design with optional fan tray
- Cordex CXCI series of system controllers provide advanced remote web based monitoring and control features

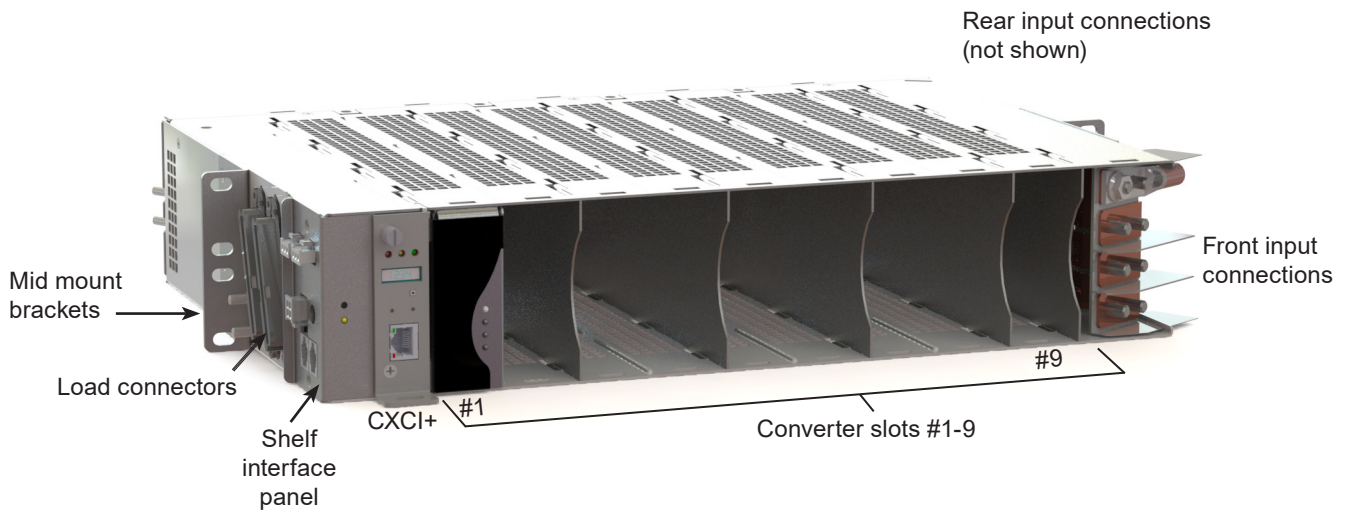

Figure 1 — LPS36 shelf (19" shown)



Figure 2 — LPS36 Compact (6" shown), cable length not to scale

The 19" and 23"LPS36 systems consist of one or more converter modules and a CXCI+ controller installed in a common shelf. A 19" shelf can have up to 9 modules, and a 23" shelf up to 12. All connections are front access. Input connections can be made at the rear of the unit as well. External connections are available at the shelf interface panel for alarm interfaces.

The LPS36 Compact packs maximum power into minimum space, but doesn't compromise on features. The shelf provides up to 16 line powering channels in the compact 2RU x 6" x 12" form. Standard system features include major and minor alarms for monitoring, connectorized cable output and one side mounting. This product is particularly suitable for remote OSP power cabinets where free rack space is tight or non-existent. With a six inch width and a single side bracket, it can be easily mounted to the side of a rack support post without using up valuable rack space.

Alpha's LPS36 modular DC to DC converter systems incorporate a full range of standard features, including current limiting and individual ground fault interrupt for each circuit. Particular emphasis is placed on recognizing a fault condition and shutting down the circuit as quickly as possible to ensure the highest level of personnel safety. Compliance with GR-1089-CORE - Class A2 provides the ability to work on the equipment while powered, which significantly reduces the administrative and labeling requirements and overheads for the high voltage wiring.

2.1 Product Part Numbers

Product	Part number
19" Shelf - 9 modules	0300055-001
19" Fan Tray	0300055-002
19" Baffle	0300055-003
23" Shelf - 12 modules	0300090-001
23" Fan Tray	0300090-002
23" Baffle	0300090-003
Input Cover Kit (19/23")	0380249-001
Alarm Cable Kit (19/23")	8700649-001
6" Shelf - 4 modules	0300189-004
6" Fan Tray	0300189-002
6" Input Lug Kit (18")	8700870-001
CXCI+ Controller	7400232-001
CXCI HP Controller	0180053-001
Converter Modules	0120011-001
Blanking Plate Kit (quantity 2)	0380070-001

2.2 Block Diagram—Three Shelves and a Fan Tray (19" and 23")

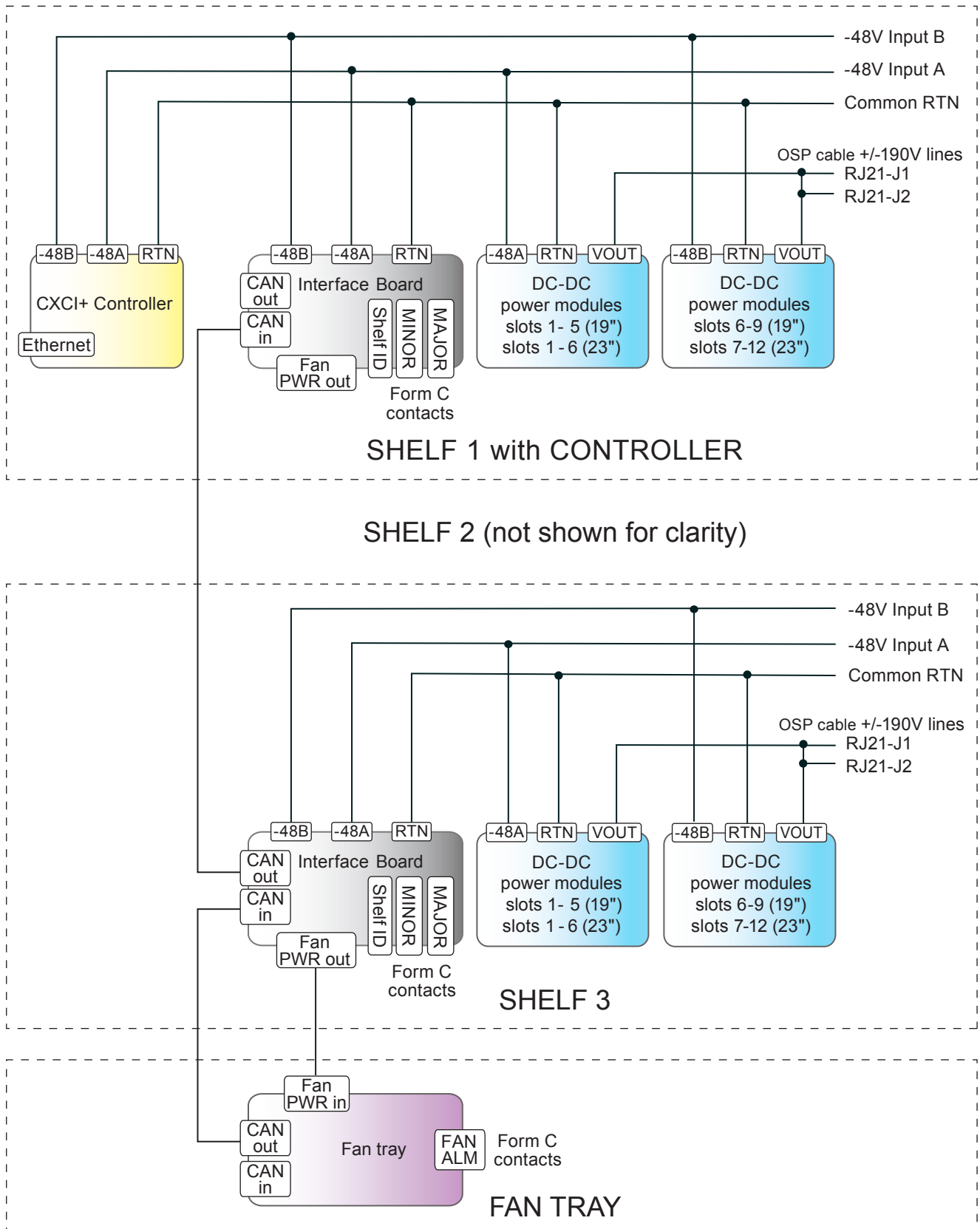

3. Product Specifications

Electrical	
Input Voltage:	-40 to -60Vdc
Recommended Breaker:	
6" Shelf:	50A per feed
19" Shelf:	70A per feed
23" Shelf:	80A per feed
Recommended Cable Size:	As per NEC 2014, Minimum #6 AWG (16mm ²) copper rated for 90°C or #4 (25mm ²) rated for 75°C
Output Voltage:	±190Vdc (RFT-V)
Power:	96W nominal per output, >92W for worst case conditions (4 outputs per module)
Efficiency:	>92%
Regulation:	<2% no load to full load
	<1% line
Output Noise:	
Wide Band:	<500mV _{RMS} (10kHz to 10MHz)
	<2.5V p-p (10kHz to 100MHz)
Acoustic:	<60dBa @ 1m (3ft), 55°C
Connections (19/23"):	
Input:	HOT: 2x sets, 1/4" holes on 5/8" centers RTN: 2x sets, 1/4" holes on 5/8" centers
Output:	Two 50-pin amp-champ style connector
Alarm	Two 5-OIN terminal blocks
Connections (6"):	
Input:	Anderson style connector
Output:	One 50-pin amp-champ style connector
Alarm	TE style connector
Quad Output Power Module (#0120011-001)	
Dimensions (HxWxD):	386mm x 35mm x 283mm (3.4in x 1.4in x 11.1in)
Weight:	0.61kg (1.4lbs)
19" Shelf - 9 Modules (#0300055-001)	
Dimensions (HxWxD):	88mm x 435mm x 311mm (3.5in x 17.1in x 12.25in)
Weight:	5.45kg (12lbs)
23" Shelf - 12 Modules (#0300090-001)	
Dimensions (HxWxD):	88mm x 536mm x 311mm (3.5in x 21.1in x 12.25in)
Weight:	7.28kg (16lbs)
6" Shelf - 4 Modules (P/N 0300189-001)	
Dimensions (HxWxD):	88mm x 149mm x 305mm (3.6in x 5.9in x 12in)
Weight:	1.5kg (3.3lbs)
Cable Length	Output: 1372mm (54.00in) Alarm: 1372mm (54.00in)

Environmental	
Temperature Operating:	
Forced Air Cooling:	- 40 to 65°C (-40 to 149°F) with minimum OSP cabinet air flow @200LFM or fan tray (used with two and three shelves)
Convection Cooling:	- 40 to 45°C (-40 to 122°F) single shelf operation only separated by 1RU baffle
Temperature Storage:	- 40 to 85°C (-40 to 185°F)
Humidity	0 to 95% RH non-condensing
Altitude:	-500 to 2000m (-1640 to 6562ft)
Heat Dissipation:	<118 BTU per hour/module
Performance/ Features	
Communication Ports:	
CAN:	Smart peripherals
Ethernet:	10/100 Base-T for TCIP/SNMP features (19"/23" systems only)
Alarm relays:	
Shelf:	1x Form C Major 1x Form C Minor
Fan Tray:	1x Form C fan tray alarm
Alarm indicating LEDs:	
Module:	One tri color LED per converter—see Table A
(19" or 23" only) Shelf:	System OK (off) Minor alarm (yellow) Major alarm (red)
Fan Tray:	Major alarm (red)
MTBF:	> 400,000 @30°C (86°F) ambient; test model Telcordia SR-332, Issue 2 (2006)
Agency Compliance	
Safety:	CSA/UL/IEC/EN No 60950-1 CSA/UL/IEC/EN 60950-21 (RFT-V circuit) CE marked
EMC:	ETSI 300 386
Emissions:	CFR47 (FCC) Part 15 - Class A Device ICES-003 - Class A Device
Immunity:	EN 61000-4-2, EN 61000-4-3 EN 61000-4-4, EN 61000-4-5 EN 61000-4-6 EN 61000-4-8
NEBS/Telcordia (19"/23" systems only):	GR-1089-CORE - Class A2 GR-63-CORE GR-3108-CORE

4. Features

4.1 Converter Modules

A module contains four isolated DC to DC converters with a common control and supervisory circuit. Each module output operates independently. An internal micro controller monitors both the inputs and outputs of the converters, turns the converters on and off, and generates a converter fail alarm if required.

4.1.1 Status Indicators

The converter module has four LED indicators – one per converter. The LEDs are color-coded to indicate converter status as follows:

Table A — Converter Status LEDs	
LED State	Converter Status
Green	Normal
Blinking Green	Remote shutdown enabled on individual channel/converter
Blinking Green (All 4 LEDs)	Shelf is not compatible with the module
	Module not seated properly
Yellow (All 4 LEDs)	Recoverable: • Ambient temperature high
Blinking Yellow (All 4 LEDs)	Input qualify not OK
Blinking Yellow	Recoverable: • OCP/Overload
	Non-recoverable: • Converter Input Fuse fail
Red	Locked-State: • OVP
	Non-recoverable: • Converter Output Fuse fail
Blinking Red	Recoverable: • GFI
OFF (All 4 LEDs)	Recoverable: • No power
	Non-recoverable: • Main Input Fuse cut-off
Chasing Red/Green Pattern (All 4 LEDs)	Locate feature enabled



4 Status LEDs—one per converter

4.1.2 Converter Alarms

Two converter fail outputs are present at the card edge connector. Alarms are activated after a one second delay for the following conditions:

- Internal regulation fails
- Output voltage $< \pm 140V$
- Over Voltage Protection (OVP) operation
- Ground Fault Interrupt (GFI) trip
- Input fuse or output fuse fail
- Output short circuit ($\pm 30V \pm 20\%$)
- Input voltage out of range
- Heatsink/ ambient temperature out of range (Over Temperature Protection - OTP)

4.1.3 Blanks

Blanks are available for blank slots. Order blanking plate kit (contains 2 blanks) #0380070-001.



NOTE:

Blanks must be installed when using fan trays to allow proper air flow to the modules, see sections 6.4.2.

4.2 LPS36 System Features (19"/23")

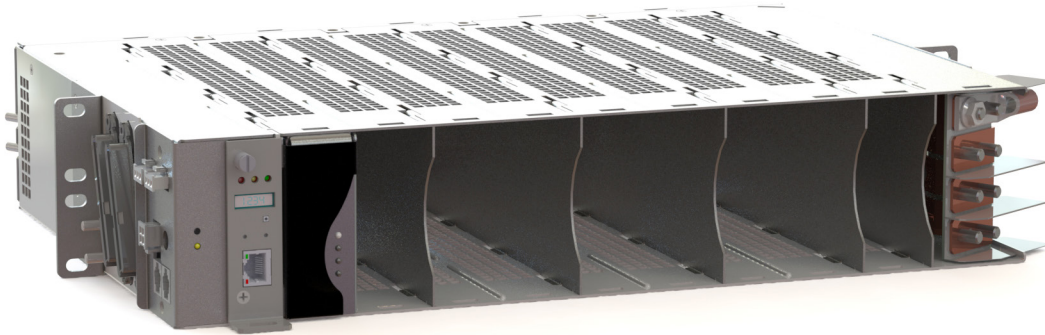

Figure 3 — LPS36 shelf (19" shown)

4.2.1 Controllers

Both the CXCI HP and the CXCI+ controllers (Figure 4 and Figure 5) can be used in the shelves. For details on using either controller go to the Alpha website to download the relevant software manual.

CXCI HP

CXCI HP in-shelf controllers have a small organic LED (OLED) display. This displays 30 characters total (six characters wide, five lines high) and the controller has three navigation buttons and one reset button. The display has three main operating modes: dashboard, menu and screen saver.

After 20 minutes with no activity, the controller goes into screen saver mode and the display shuts off. From screen saver mode, press any of the three navigation buttons to re-activate the screen and enter dashboard mode.

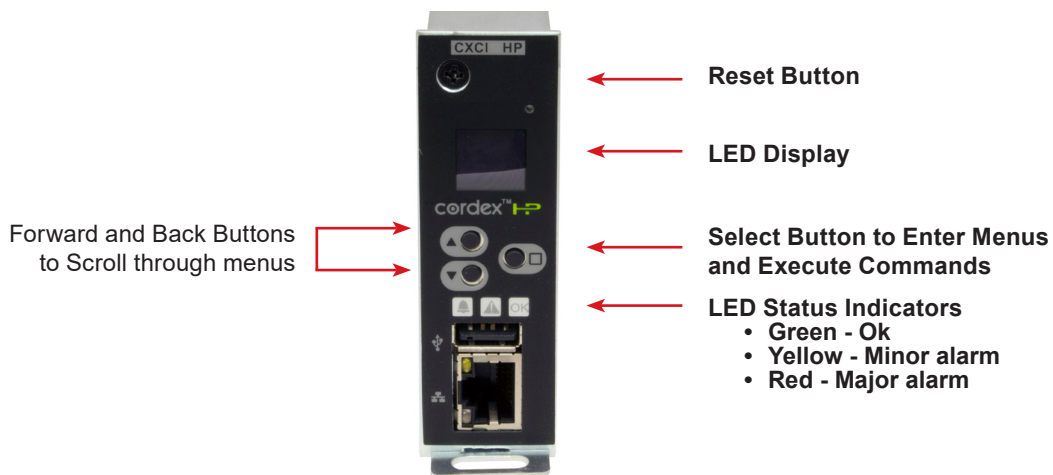

Figure 4 — CXCI HP controller front panel

CXCI+ Controller

The controller brings advanced monitoring technology to the Cordex series of converters. A single controller manages up to 9 converter modules. This compact system controller is equipped with the complete range of Cordex software features, including the following:

- Ethernet port for local and remote communications
- User definable alarms
- Daily logging of power system events and system statistics

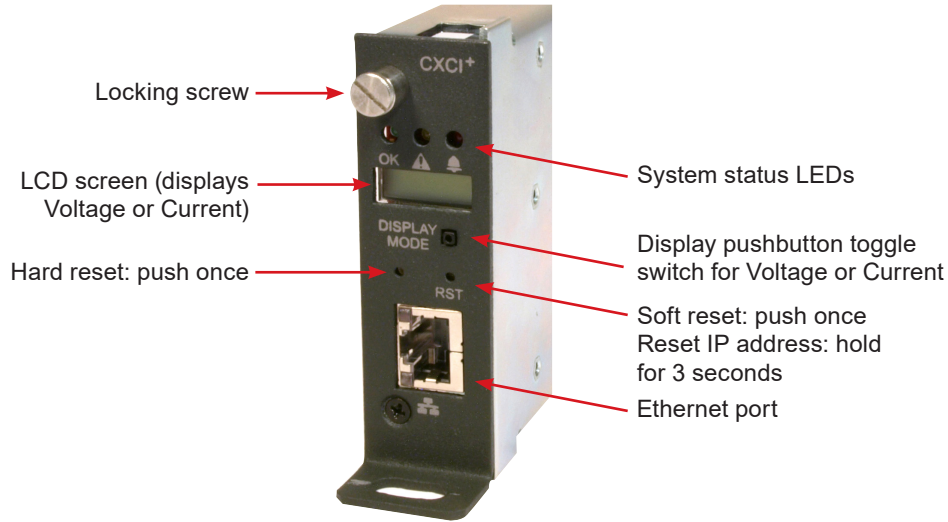

Figure 5 — Cordex CXCI+ controller front panel

LEDs

Each controller has three LEDs located on the front panel. These are used to display the alarm status of the power system, controller progress and status during startup, as well as file transfers.

Alarm Conditions

The controller illuminates the LED that corresponds to the system alarm status. Only one LED is illuminated at a time during alarm conditions. The following show the corresponding alarm status for each LED color:

- Green:** OK, no alarms
- Yellow:** Minor alarm, no major alarms
- Red:** Major alarm

Progress and Status Indication

The LEDs are also used in the following situations:

- Base unit validation – all three LEDs are on at the same time.
- File transfer – when recovering from invalid firmware application – the red LED is illuminated.

Reset

Refer to Section "Controller Reset" on page 53 for reset options.

4.2.2 Shelf Connections and Indicators (19" and 23" only)

Connections to the load and local alarm-sending unit are conveniently located on the side of each shelf.

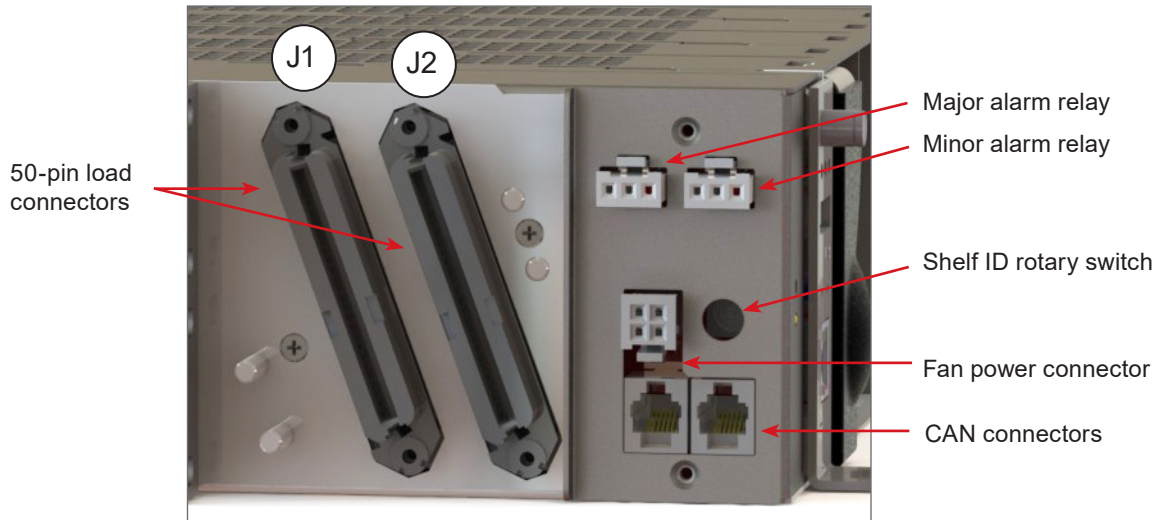

Figure 6 — Shelf Connections

4.2.3 Alarm Relays (Form C Contacts)

The converter shelf has an interface panel with terminal blocks for Major and Minor alarm outputs (Form C contacts), which are controlled by the controller. The Major alarm relay is designed to “fail safe” to ensure the alarm is registered when power is removed.

Major Alarm

The Major alarm relay de-energizes under any one of the following conditions:

- When two or more outputs have failed within a shelf
- When the DC input feed is below the normal operating voltage
- When the DC input feed is above the normal operating voltage



NOTE:

If a Major alarm is activated, it "resets" the Minor alarm relay to an energized state.

Minor Alarm

The Minor alarm relay is de-energized under any one of the following conditions:

- Single output has failed within a shelf
- Internal ambient temperature is out of range

Alarm LEDs

On the front of the interface panel, are two LEDs—one red and one yellow, which indicate the shelf alarm status (Figure 7).



Figure 7 — Shelf Alarm LEDs

4.2.4 Fan Tray and Baffle Tray

The optional fan tray and baffle tray are each 1RU high (Figure 8). Typically they are mounted together directly below the LPS36 shelf assembly.

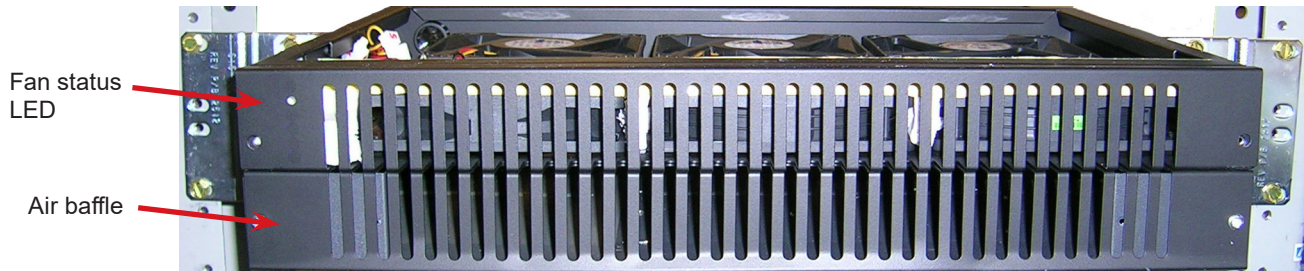

Figure 8 — Fan and Baffle Tray Rack, mounted (19" shown)

The fan tray has six fans with a total minimum flow of 200 CFM. The fans are powered from the LPS36 shelf directly above it. If any fan fails, a status LED on the front panel turns red (Figure 8). The fan tray also has a Form C fan fail alarm relay that can be connected to a local alarm-sending unit, see Figure 25 on page 33.

4.2.5 Mounting 19" Equipment in a 23" Rack

To mount a 19" shelf in a 23" rack, order 2x 2RU universal mounting brackets #5901456-002.

To mount a 19" fan or baffle tray in a 23" rack, order 2x 1RU universal mounting brackets #5901456-001.

4.2.6 Alarm Cable Kit

Terminal blocks for major and minor alarms use Molex connector 39-01-4031. This connector mates with Alpha alarm minifit JR. receptacle 5566-03A3-210. Kit #8700649-001 is available from Alpha with 1 connector.

4.3 LPS Compact System Features (6")

4.3.1 Shelf Connections

Connections to the load and local alarm-sending unit are conveniently located on the side of each shelf.

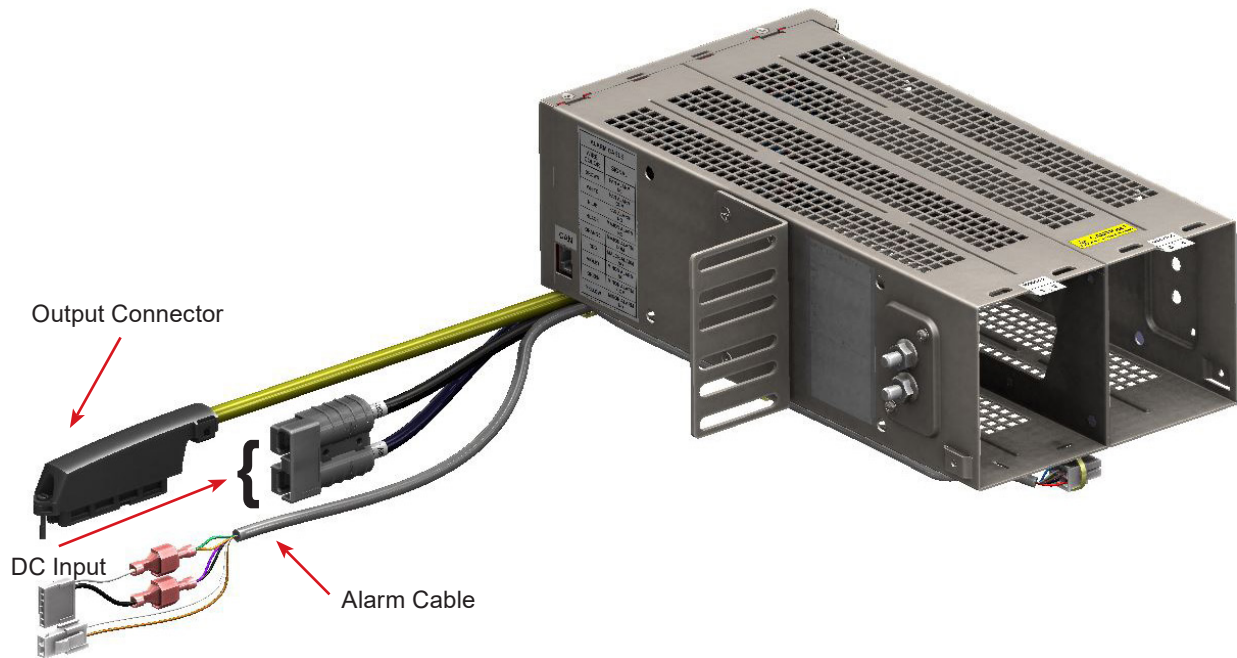

Figure 9 — Shelf Connections

4.3.2 Alarm Relays (Form C Contacts)

The LPS Compact system has Major and Mintr alarm outputs (Form C contacts). The Major alarm relay is designed as a "fail safe" to ensure that the alarm is registered when power is removed.

Major Alarm

The Major alarm relay de-energizes under any one of the following conditions:

- When two or more outputs have failed within a shelf
- One -48V input below 40V
- One -48V input is greater than -60V

Minor Alarm

The Minor alarm relay is energized under any one of the following conditions:

- Single output failed within a shelf
- Internal ambient temperature out of range

4.3.3 DC Input Cable Kit (ordered separately)

The Anderson connector can be used or mated with Alpha part number 8700870-001 which provides two #8AWG wires with 2 hole lugs. Check label on wire for connecting to proper polarity.

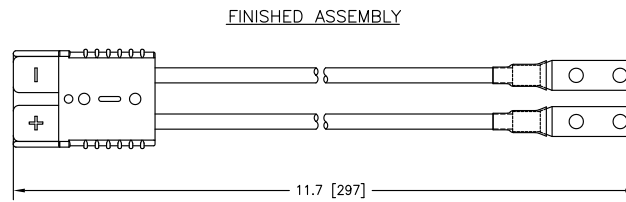

Figure 10 — DC input cable kit accessory (ordered separately, PN 8700870-001)

4.3.4 Fan Tray

Refer to the fan tray installation section.



Figure 11 — Fan tray

5. Site Evaluation and Pre-Installation

5.1 Pre-Installation Requirements

5.1.1 Effective Capacitance

The effective capacitance of each output of the LPS36 is 2.7 microfarads maximum between the output connections to the telecommunications network and 0.5 microfarads between each output connection to the telecommunications network and earth ground.

- At the time of installation, carry out a system assessment to ensure that the effective capacitance of the total system, including the capacitance of the LPS36 system, does not exceed 11 μ F (line to earth) and 40 μ F (line to line).

5.1.2 RFT-V Circuits

- At the time of installation, ensure that the voltage rating of the wiring of the telecommunication network is adequate for the normal RFT circuit voltage (+/-200Vdc), together with superimposed transients.
- Ensure that the circuits to be connected together are all RFT-V circuits.

5.1.3 Primary Protection

The LPS36 has built-in second level surge protection in compliance with the GR-1089 requirement. Primary protection must be in place at the customer site. External primary surge protection devices are necessary to optimally protect the RFT-V circuits from lightning surge and maintain safety certification to UL/CSA 60950-21.

Each channel (pair) must be properly protected by the upstream system using a 5-pin protector to a level corresponding to a Bourns 2410 Series. For example: 2410-33-G-MSP-S provides the part in a red color. This protector should be UL 497 listed and rated for 300-400 Volts voltage breakdown range.

5.1.4 Transient Response

The LPS36 has been designed to provide protection against typical input and output voltage surges. For example, in the event of any single isolated 75 Vdc/9.5ms overvoltage transient being applied between the input power terminals, the LPS36 will continue to operate properly, and will not be damaged or degraded in performance.

However, the RFT-V output may exhibit a momentary voltage over/under-shoot by as much as 25% of the nominal output voltage, depending on the characteristics of the equipment being connected as a load. The down-converter connected at the remote end is expected to tolerate this dynamic line voltage swing.

In the event of lightning surges and AC power faults, the RFT-V output ports of the LPS36 will experience voltage surges of up to a few thousand volts, but the equipment will not be damaged, and will continue to operate without manual intervention after normally expected electrical stresses and transients (i.e. first-level surges), and will remain safe under less frequently encountered severe stresses and transients (i.e. second-level surges).

For critical application that requires a more robust system such that any momentary interruption on the remote end is not acceptable (as caused by input or output transients described above), Alpha recommends using the AlphaCap 665 Short Duration Backup Supply Module (p/n 013-015-20) in conjunction with Alpha CSM46.







For more information on this subject, please refer to Telcordia Technologies Generic Requirements document for Electromagnetic Compatibility (EMC) and Electrical Safety – Generic Criteria for Network Telecommunications Equipment (GR-1089-CORE).

5.2 Packing Materials

Alpha is committed to providing products and services that meet our customers' needs and expectations in a sustainable manner, while complying with all relevant regulatory requirements. As such Alpha strives to follow our quality and environmental objectives from product supply and development through to the packaging for our products.

Rectifiers and batteries are shipped on individual pallets and are packaged according to the manufacturer's guidelines.

Almost all of Alpha's packaging material is from sustainable resources and or is recyclable. See the following table for the material and its environmental codes.

 20 PAP/PCB	 01 PET	 04 PE-LD	 06 PS	 40 FE	 41 ALU	 50 NW
Cardboard	Polyethylene Terephthalate	Low Density Polyethylene	Polystyrene	Steel	Aluminum	Wood
Packing boxes Caps	Flexible film Packaging	Bubble wrap Shrink wrap Plastic bags	Foam	Strapping on pallets	Strapping on pallets	Pallets Lumber

5.2.1 Returns for Service

Save the original shipping container. If the product needs to be returned for service, it should be packaged in its original shipping container. If the original container is unavailable, make sure that the product is packed with at least three inches of shock-absorbing material to prevent shipping damage.

Alpha Technologies is not responsible for damage caused by improper packaging of returned products.

5.2.2 Check for Damage

Before unpacking the product, note any damage to the shipping container. Unpack the product and inspect the exterior for damage. If any damage is observed, contact the carrier immediately.

Continue the inspection for any internal damage. In the unlikely event of internal damage, inform the carrier and contact Alpha Technologies for advice on the impact of any damage.

5.2.3 General Receipt of Shipment

The inventory included with your shipment depends on the options you have ordered. The options are clearly marked on the shipping container labels and bill of materials.

Call Alpha Technologies if you have any questions before you proceed: 1 888 462-7487.

6. LPS36 System Installation

This chapter is provided for qualified personnel to install an LPS36 system.

6.1 General Instructions

This chapter provides cabling details and notes on cable sizing for DC applications.

Connections to the converter system must comply with all the local codes and ordinances.

6.2 Safety Precautions



WARNING!

The DC input to the modules (and the converter system) – though not dangerous in voltage – has a high short circuit current capacity that may cause severe burns and electrical arcing.

The DC output is a potentially dangerous voltage. Do not touch the output connections when under power. Ensure that power has been removed from the outputs before working on them.



WARNING!

The intra-building ports (Ethernet, CAN, alarm relays) of the equipment or subassembly are suitable for connection to intra-building or unexposed wiring or cabling only. The intra-building port(s) of the equipment or subassembly MUST NOT be metallicity connected to interfaces that connect to the OSP or its wiring. These interfaces are designed for use as intra-building interfaces only (Type 2 or Type 4 ports) and require isolation from the exposed OSP cabling. The addition of Primary Protectors is not sufficient protection in order to connect these interfaces metallicity to OSP wiring.



WARNING!

CXCI+ controller Ethernet port is not designed to withstand lightning and AC power cross surges according to the NEBS requirements in GR-1089-CORE. Ensure that any Ethernet cable used (not provided by Alpha) does not exceed a maximum length of 6 meters.

Before working with any live power system, take the following precautions:

- Remove all metallic jewelry; e.g., watches, rings, metal rimmed glasses, necklaces.
- Wear safety glasses with side shields (and prescription lenses if necessary) at all times during installation.
- Use insulated metallic tools.

Installers should follow all applicable local rules and regulations for electrical and battery installations; e.g., CSA, UL, CEC, NEC, OSHA, and local fire codes.



CAUTION!

The LPS36 is suitable for connection to the Central Office (NEC)

The LPS36 must be grounded via a copper ground conductor.

Before making connections all bare grounding connection points to the LPS36 must be cleaned and coated with an anti-oxidant solution.

Before making connections all surfaces on the LPS36 that are un-plated must be brought to a bright finish and treated with an anti-oxidant solution.

To ensure electrical continuity, all non-conductive surfaces on the LPS36 should be removed from all threads and all connection points.

The LPS36 utilizes a 2-hole compression lug with a #6 AWG wire that utilizes 8.8 ft-lbs torque to secure it to the frame and LPS36.

6.3 Tools Required

Various insulated tools are essential for product installation. The following list is a guide:

- Phillips head screwdriver, #2 (tip size 3/16")
- Slot head screwdriver (blade size 1/8")
- Digital voltmeter equipped with test leads
- Cutters, crimpers, and wire strippers 0.25 to 10mm² (#24 to #6 AWG)

6.4 Thermal Management

This section provides supplemental information regarding thermal management of the LPS36.

✓ NOTE: 1

Blanking plates must be installed in all the empty converter slots when forced air or fan cooling is used for the application.

✓ NOTE: 2

When the LPS36 is operating normally at maximum rated load, the shelf level rate of heat dissipation exceeds the allowable limit of 27.9 W/sq.ft. per Section 4.1.6 of GR-63-CORE (Issue 6).

Alpha recommends leaving a minimum of 27.3 (22.9) inches vacant vertical rack space for each 23" (19") shelf installation to meet the required shelf-level rate of heat dissipation. In addition, special equipment room cooling may be required.

6.4.1 Natural Convection ($T_a = -40^{\circ}\text{C}$ to $+45^{\circ}\text{C}$) — One Shelf Only

The high efficiency of LPS36, given its high power density, makes it possible to operate up to 45°C ambient at full power without the need for fan tray or external airflow for **one shelf only**. When installing the LPS36 Shelf in a CO type installation that only relies on natural convection for cooling, proper spacing from surrounding equipment should be observed to facilitate effective ventilation as shown below in Figure 12.

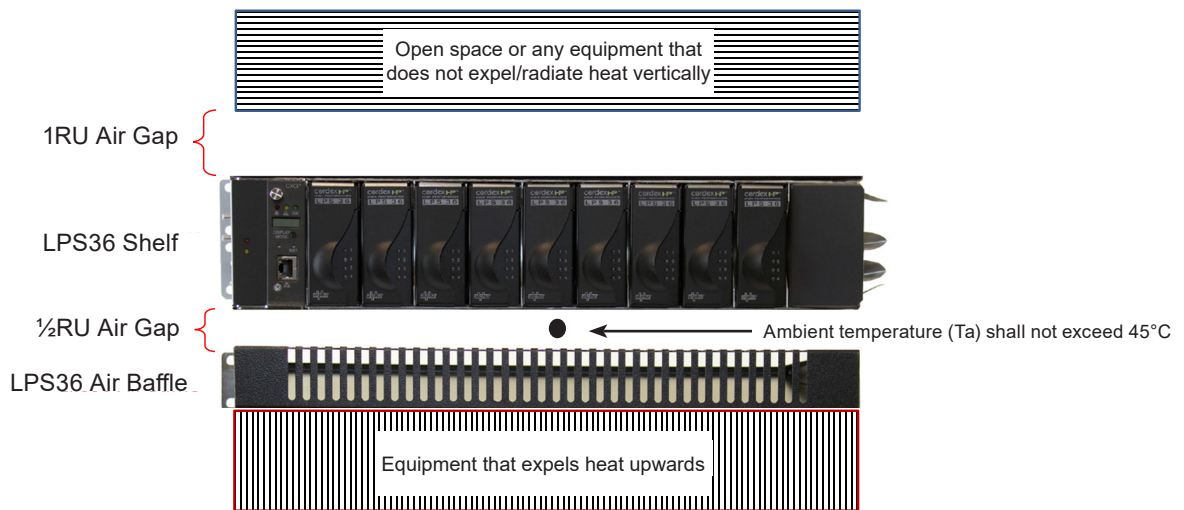

Figure 12 — Natural Convection 19"/23" Systems



CAUTION!

CAUTION: For natural convection cooling the only orientation that can be used is the one pictured in Figure 12.

The temperature below the LPS36 shelf shall not exceed 45°C. If the temperature exceeds 45°C, then the output power is derated at 2.5W/°C as per the graph below.

NOTE:

LPS36 Average Output = Line loss (I^2R) + Remote down-conversion + Remote equipment load.

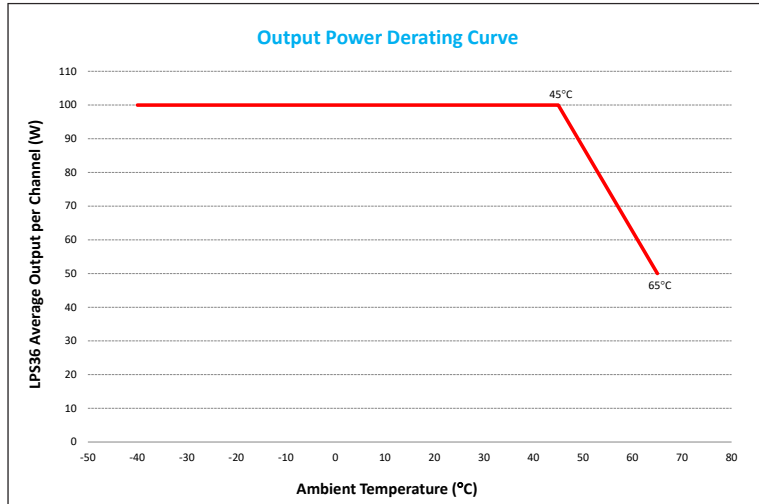

Figure 13 — Output Power Derating Curve

6.4.2 Forced Air Cooling with LPS Fan Tray — Two and Three Shelves

Two and three shelves require a fan tray and two baffles to meet the specified cooling requirements for both CO and OSP applications. Install the fan tray directly below either two or three converter shelves and a baffle tray below the fan tray as shown below in Figure 14. In addition, install a baffle tray above the converter shelves.

Up to nine converter shelves can be managed by a single controller, provided each three contiguous shelves has fan cooling.



Figure 14 — Multi-shelf System Mounting

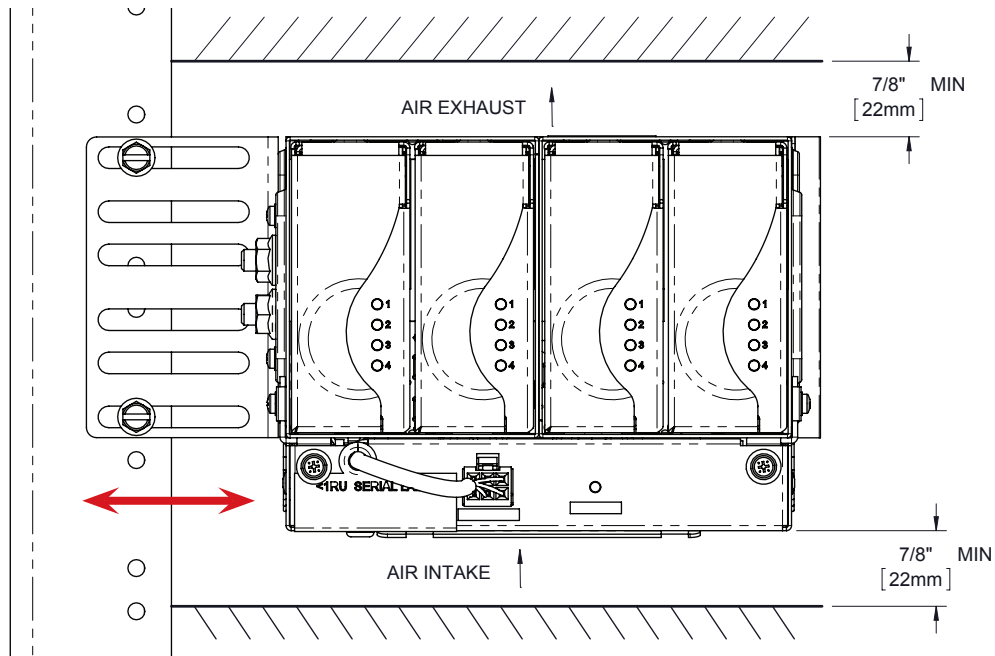

Figure 15 — LPS36 Compact Shelf with Fan Tray

6.4.3 LPS in OSP Cabinet Application

For operations where ambient temperature reaches 65°C maximum, forced air cooling is required. The LPS36 module has some flexibility to operate in high ambient temperature without using the standard LPS fan tray by utilizing the internal airflow inside the OSP cabinet.

Thermal testing must first be conducted on the cabinet with test results reviewed and approved by Alpha.

To determine the external airflow required for a given load, follow the graph below.

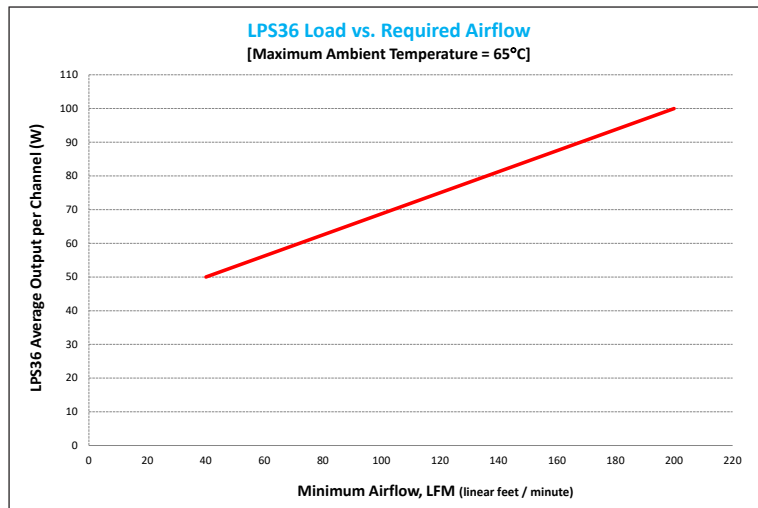

Figure 16 — Minimum Air Flow

6.5 LPS36 Set Up: 19" and 23" Systems

6.5.1 Rack Mounting

NOTE:

Use thread forming screws with paint piercing washers to connect the LPS36 shelves and fan assembly to the frame.

Use universal mounting brackets to mount the LPS36 shelf in a 19" or 23" rack. For bracket part numbers see section "4.2.5 Mounting 19" Equipment in a 23" Rack" on page 19.

6.5.2 Shelf ID

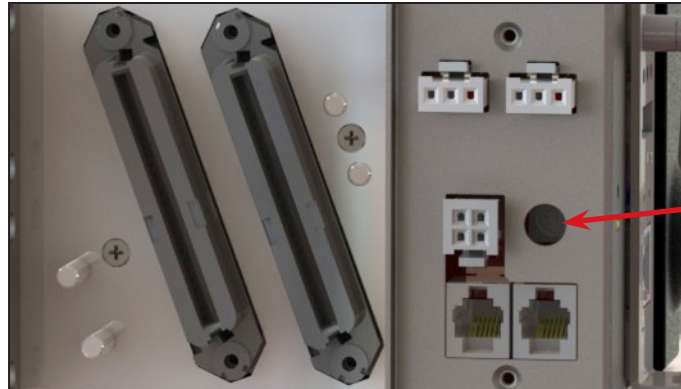

Set the rotary dial to a unique shelf ID before mounting. Do not use 0.

6.5.3 Input and Output Wiring (19"/23")

This power system is suitable for installation as part of a Common Bonding Network (CBN) and is intended to be used in a DC-I configuration (isolated from frame ground).

This system is intended to be used with a -48Vdc rectifier/ battery system at the input, and surge protectors and line terminators at the output.

6.5.4 Wiring Chassis Ground

NOTE:

Ground connections are bright electro tin plated class B as per ASTM B545-97 Class B. No antioxidant is required before crimp connections are made.

Protective earthing terminals are provided for chassis ground—two pair at the side and one pair at the rear (Figure 17).

1. Connect the power system chassis to the building master ground bus (MGB). This connection is necessary for personnel safety and to meet many telco-grounding requirements.
2. Use minimum #6 AWG (16mm) copper wire and standard 2-hole crimp lugs for 1/4" studs on 5/8" centers.
3. Secure the lugs with #10-32 serrated flanged nuts (supplied) to provide the anti-rotation necessary for primary ground connections.

Recommended torque values	
#10-32	45 in-lbs.

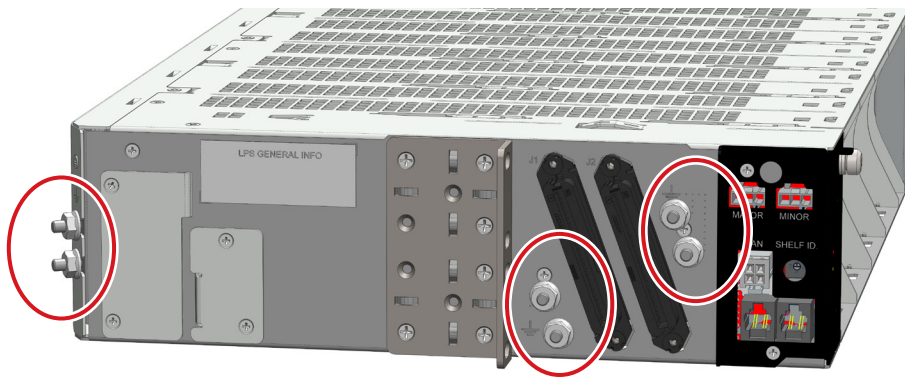

Figure 17 — Locations for protective earthing terminals for chassis ground (LPS36 side view)

6.5.5 Connecting the DC Input

NOTE:

Connect the LPS36 to a Safety Extra Low Voltage (SELV) <60VDC input power circuit.

Connections are provided for either side-front or side-rear access (Figure 18).



Figure 18 — DC input connections (19")

WARNING!

Ensure input feeder breakers are off before connecting inputs. Hazardous voltages and/or energy levels are present at the input of power systems.

Each shelf has two negative inputs, A and B and two connections to a positive common input. Half the converters are powered by feed A and half by feed B as listed in the following table.

Alpha recommends that each converter shelf have two dedicated input feeder breakers, if both A and B feeds are used.

Refer to the specifications in Section 3 on page 13 for recommended breaker and cable sizes. Local electrical codes have precedence.

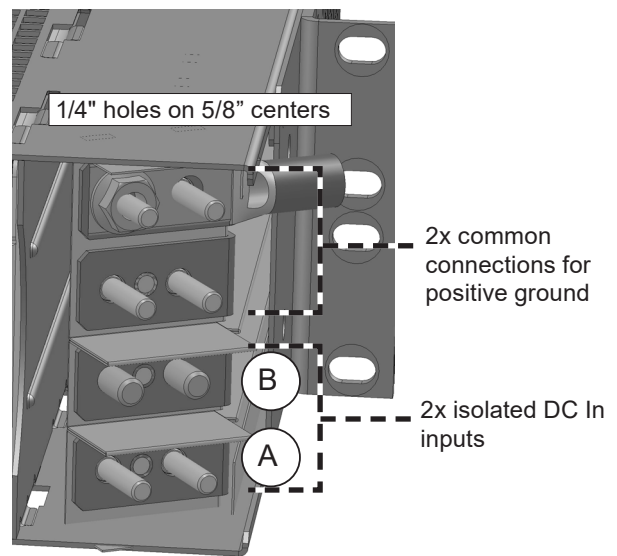

Figure 19 — DC input wiring connections

Table B — DC input wiring connections		
Shelf width	Feed A to Converter Slots	Feed B to Converter Slots
19"	1-5*	6-9*
23"	1-6*	7-12*

*Slots are numbered from left to right when viewed from the front.

6.5.6 Making CAN Bus Connections

Each module communicates with the controller using CAN protocol. The modules report alarms, converter output voltages, ambient temperature and the location of the module within a cabinet.

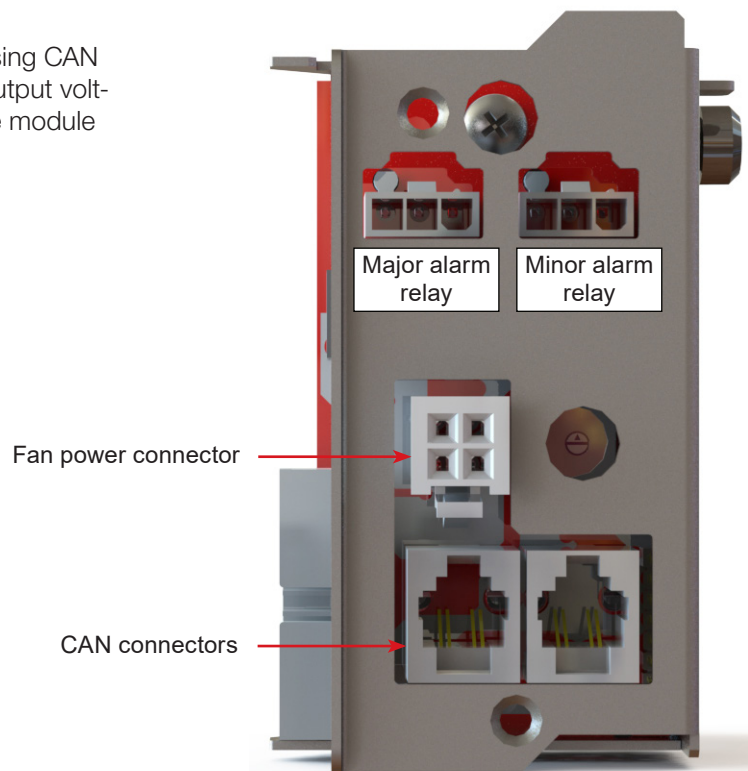

Figure 20 — CAN and fan connections on the shelf interface panel (for reference only)

1. Connect the daisy-chained CAN bus cable from the top shelf to the last shelf or fan tray. Figure 22 shows the wiring for three shelves and a fan tray.
2. Insert the CAN terminator (P/N 5450228-001) in the last CAN OUT location. See Figure 21.

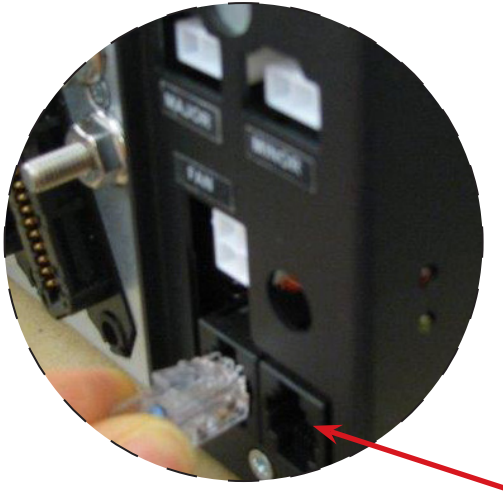

Figure 21 — CAN OUT terminator

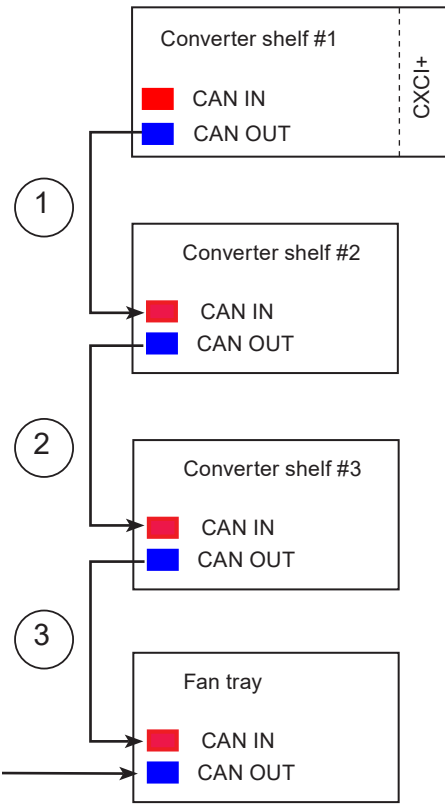

Figure 22 — CAN Bus cabling



NOTE:

The CAN terminator ships in the plastic bag with the Installation & Operation manual.

6.5.7 Connecting Power to the Fan Tray

Power to the fans is provided by the converter shelf immediately above it. Plug the cable from the fan tray into the receptacle labeled FAN PWR in the converter shelf above it (see Figure 20 on page 31).

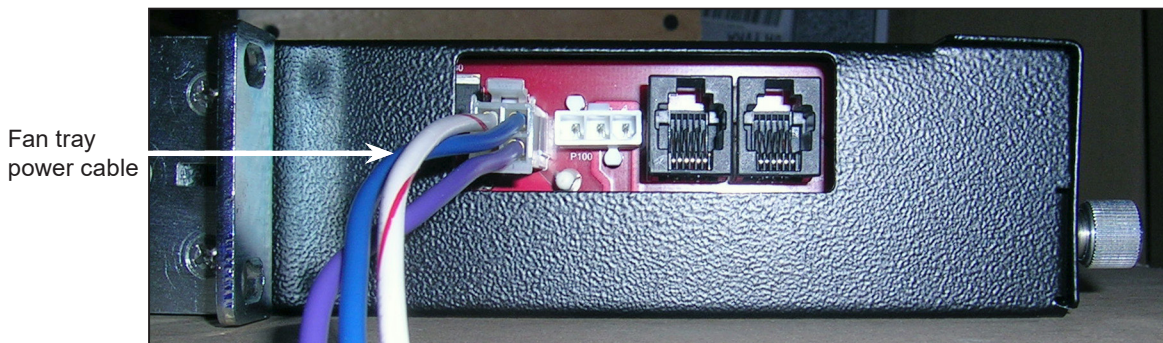

Figure 23 — Fan tray connections

6.5.8 Wiring the Alarm Relays

6.5.9 Converter Shelf

Two form C relay contacts are available for Major and Minor alarms.

Connect the relays (located on the side of the controller-side of the shelf) to the local alarm-sending unit using wire gauges from #28 to #16 AWG (0.08 to 1.31 mm²). The NO/C/NC positions for each alarm are shown here.

Outputs from the alarm relays can be ganged to produce one alarm at the alarm-sending unit.

NOTE: Terminal blocks for major and minor alarms use molex connector 39-01-4031. It mates with Alpha alarm minifit JR. receptacle 5566-03A3-210. Kit #8700649-001 is available with one connector.

Major Alarm Relay		
Alarm Condition Present?	NC to C	NO to C
No	Open	Closed
Yes	Closed	Open
Minor Alarm Relay		
Alarm Condition Present?	NC to C	NO to C
No	Open	Closed
Yes	Closed	Open

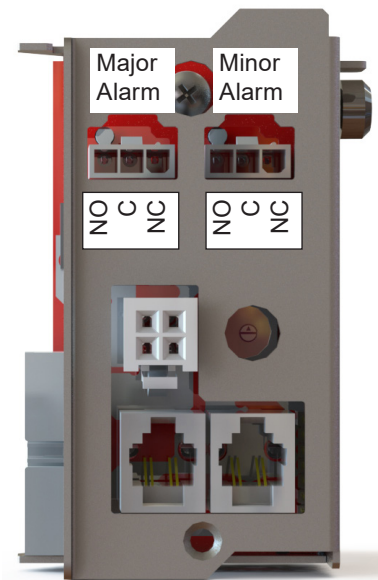

Figure 24 — Converter shelf alarm relays

6.5.10 Optional Fan Tray

Failure of a fan generates a Major alarm. The form C relay, on the side of the fan tray, can also be connected to the local alarm-sending unit. Use wire gauges from #28 to #16 AWG (0.08 to 1.31 mm²). The NO/C/NC positions for each alarm are shown in Figure 25.

Outputs from the alarm relays can be ganged to produce one alarm at the alarm-sending unit.

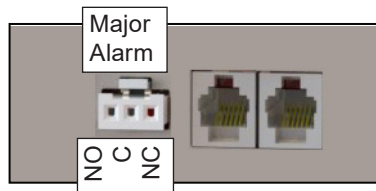

Figure 25 — Fan Tray Alarm Relay

6.6 LPS Compact Set Up: 6" Systems

Use the bracket provided to mount LPS36 Compact shelf to a structural component, typically one side of an equipment rack or a frame inside an outside plant enclosure. The bracket can be assembled to the left or right side of the shelf depending on the installation.

When a fan tray is used, the shelf can be in any orientation depending on the space available. When a fan tray is not used, the LPS36 Compact can only be orientated in the normal, upright position. In both situations, pay attention to air flow requirements around the shelf.

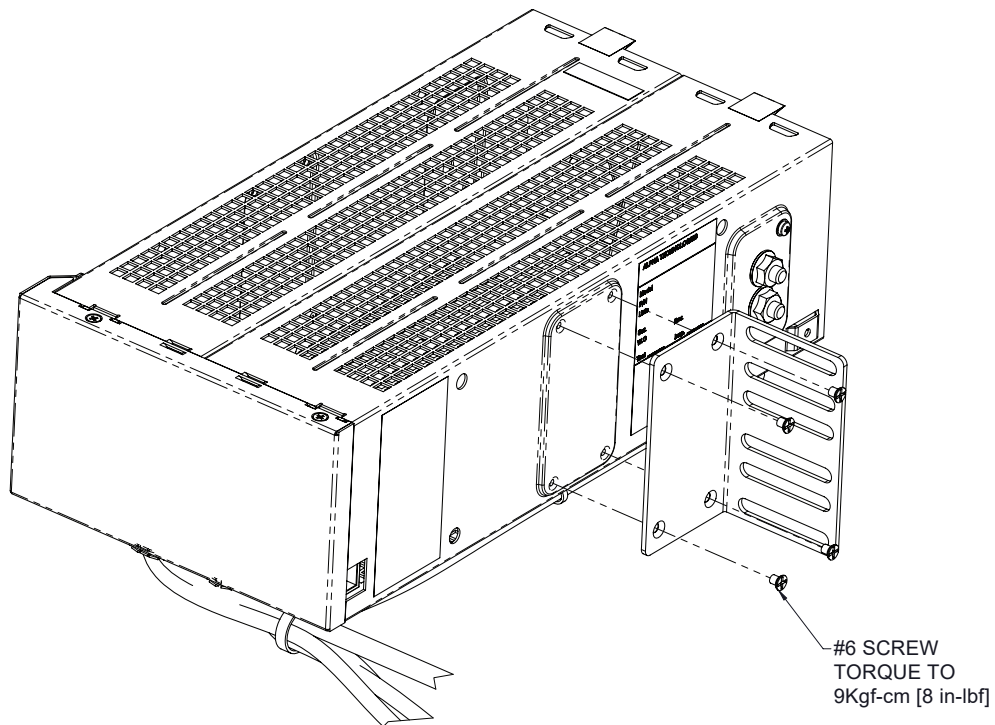

Figure 26 — Rack Mount Bracket Assembly (either side, based on installation)

6.6.1 LPS Compact Mounting Options

Mounting without a Fan Tray

Without a fan tray the shelf can only be mounted in the 'right-side-up' position as shown below. The bracket can be installed on either the right- or left-side of the shelf.

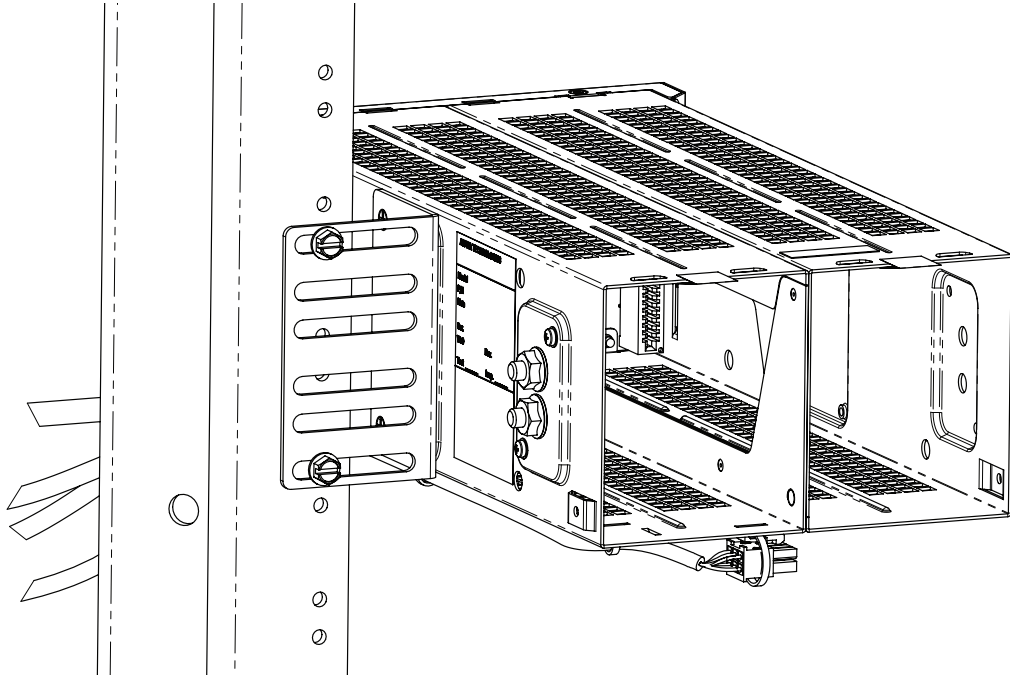

Figure 27 — Rack Mount (left side shown)

Mounting with a Fan Tray

Additional options are available when using the LPS Compact fan tray accessory.

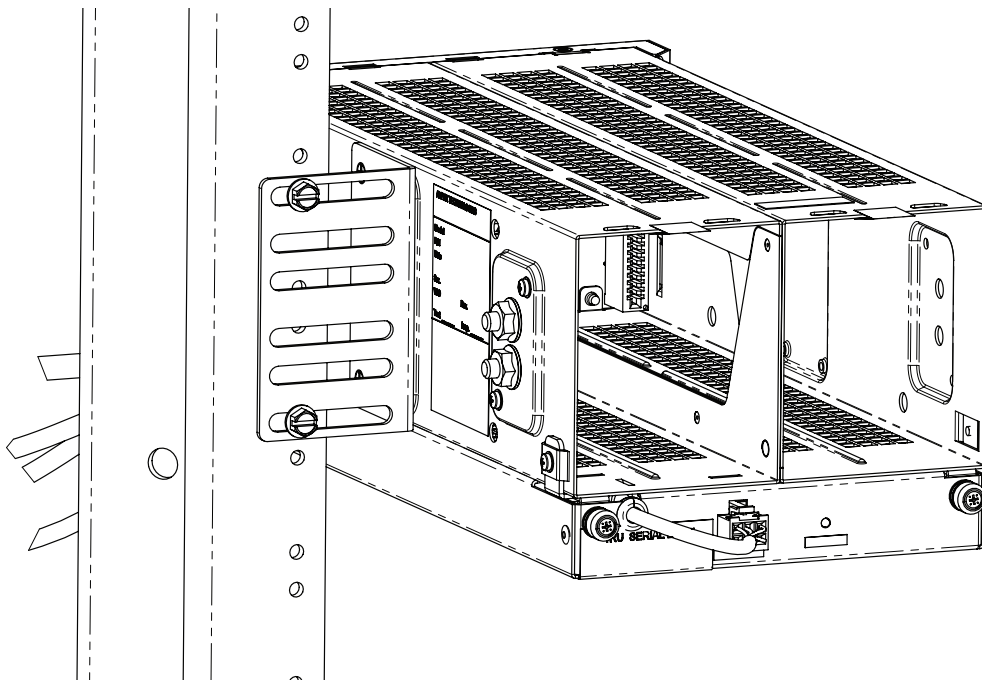

Figure 28 — Rack Mount, Left side with Fan Tray

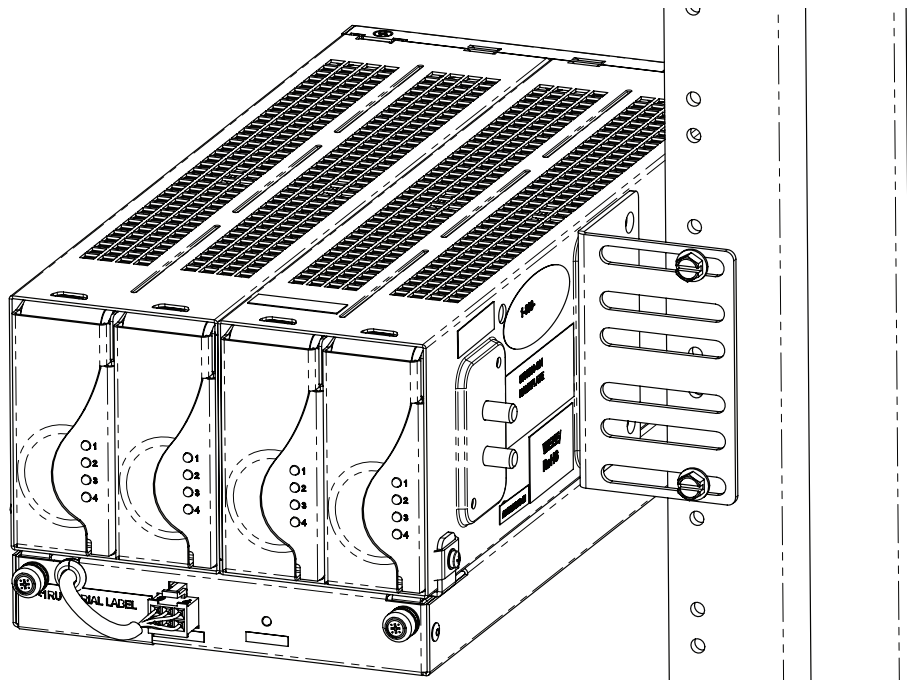

Figure 29 — Right Side Mount, with Fan Tray

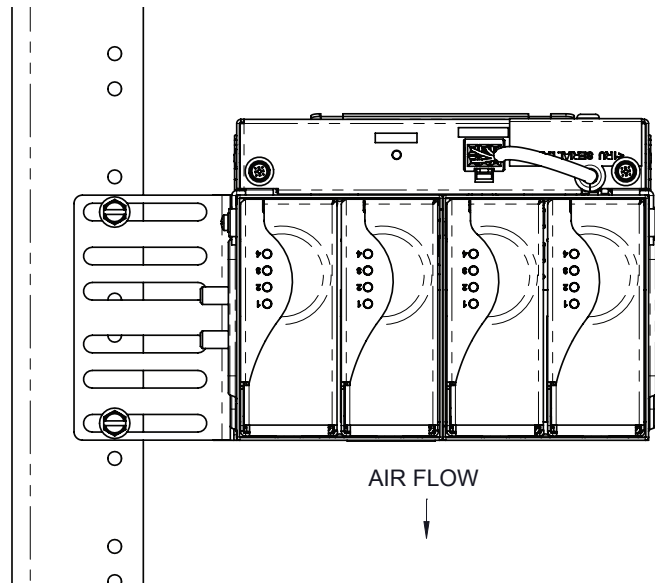

Figure 30 — Rack Mount Left Side, LPS modules upside down

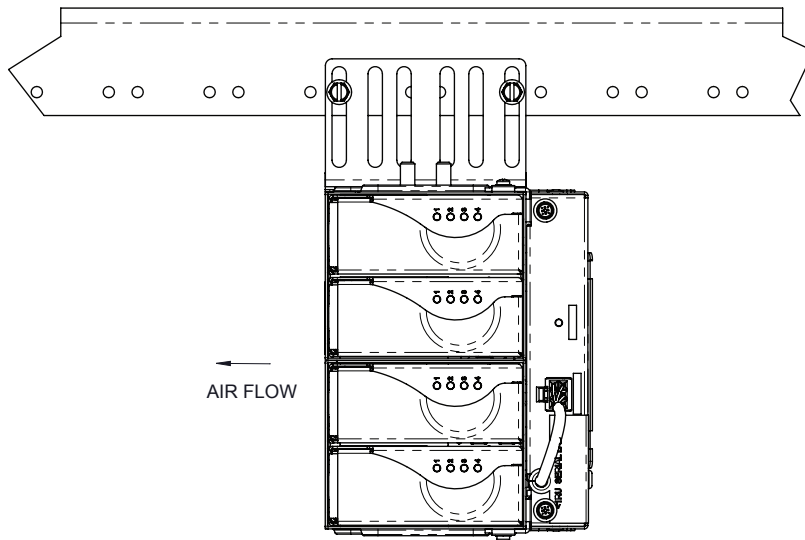

Figure 31 — Mounted Sideways (front of unit)

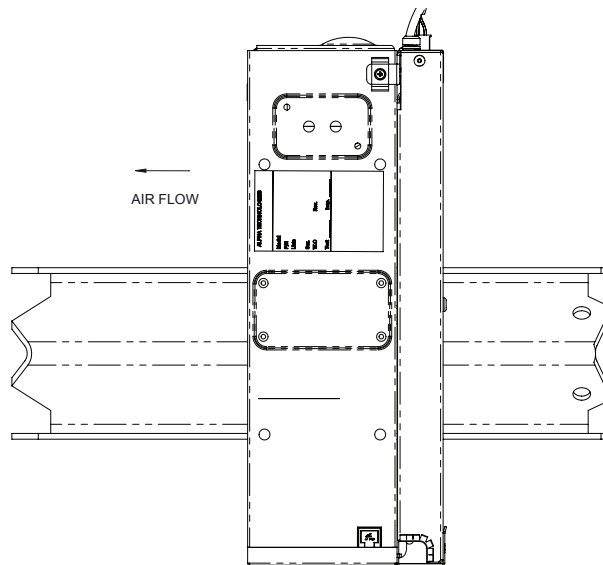
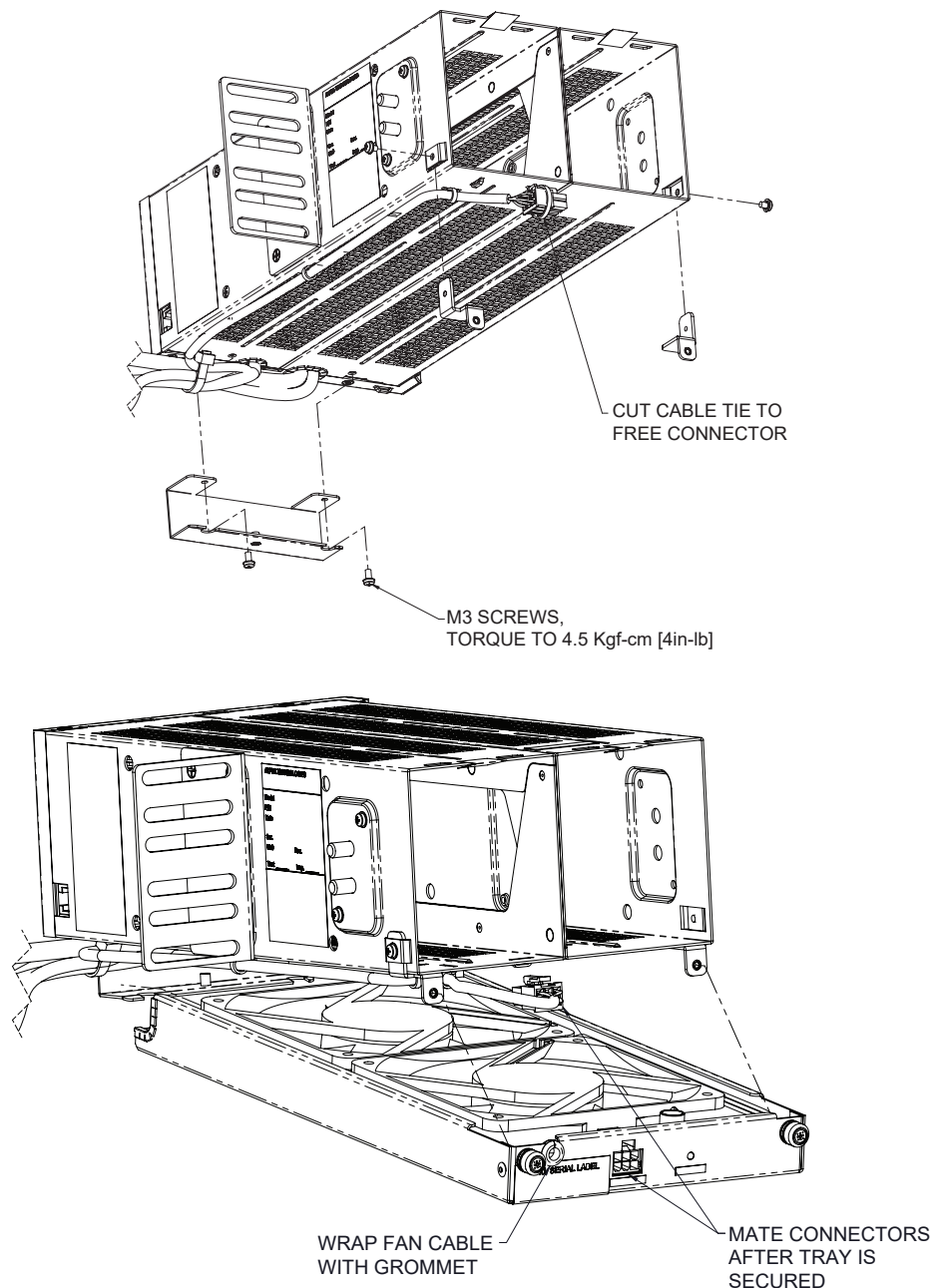

Figure 32 — Mounted Sideways (back of unit)

6.6.2 Fan Tray Installation

Fan tray installation should be completed before the shelf is mounted to the rack.

1. Assemble the fan holding cradle to the rear bottom of the shelf, secure with two screws.
2. Attach two fan mount brackets to the front, left and right side of the shelf and secure with screws on both sides.
3. Cut the cable tie holding the fan connector to free the fan wire.
4. Remove the wire grommet from the fan tray and wrap it on fan wire about 1-1/2" from the connector.
5. Slide the back side of the fan tray to the cradle at an angle.
6. Insert the wire grommet back to the slot with fan wire, and then move the fan tray front into position so that the two thumb screws can be engaged and tightened.
7. Plug the fan connector to the fan tray.



6.6.3 Input and Output Wiring (6" shelf)

This power system is suitable for installation as part of a Common Bonding Network (CBN) and is intended to be used in a DC-I configuration (isolated from frame ground).

This system is intended to be used with a -48Vdc rectifier/ battery system at the input, and surge protectors and line terminators at the output.

6.6.4 Wiring Chassis Ground

Protective earthing terminals are provided for chassis ground at the left front side of LPS36 Compact. If necessary, the terminal can be moved to the right side. Undo the two screws securing the terminal plate and move it to the right side, use the same two screw to secure the terminal plate.

1. Connect the power system chassis to the master ground bus (MGB). This connection is necessary for personnel safety and to meet many telco-grounding requirements.
2. Use minimum #6 AWG (16mm) copper wire and standard 2-hole crimp lugs for 1/4" studs on 5/8" centers.
3. Secure the lugs with 1/4-20 serrated flanged nuts (supplied) to provide the anti-rotation necessary for primary ground connections.
4. The screws for securing the ground terminal plate can also be reoriented on the opposite side of the module.

For additional information refer to the Customer Connections drawings at the end of this manual (0300189-08).

Recommended torque values	
1/4-20	105 in-lb [12 N-m]

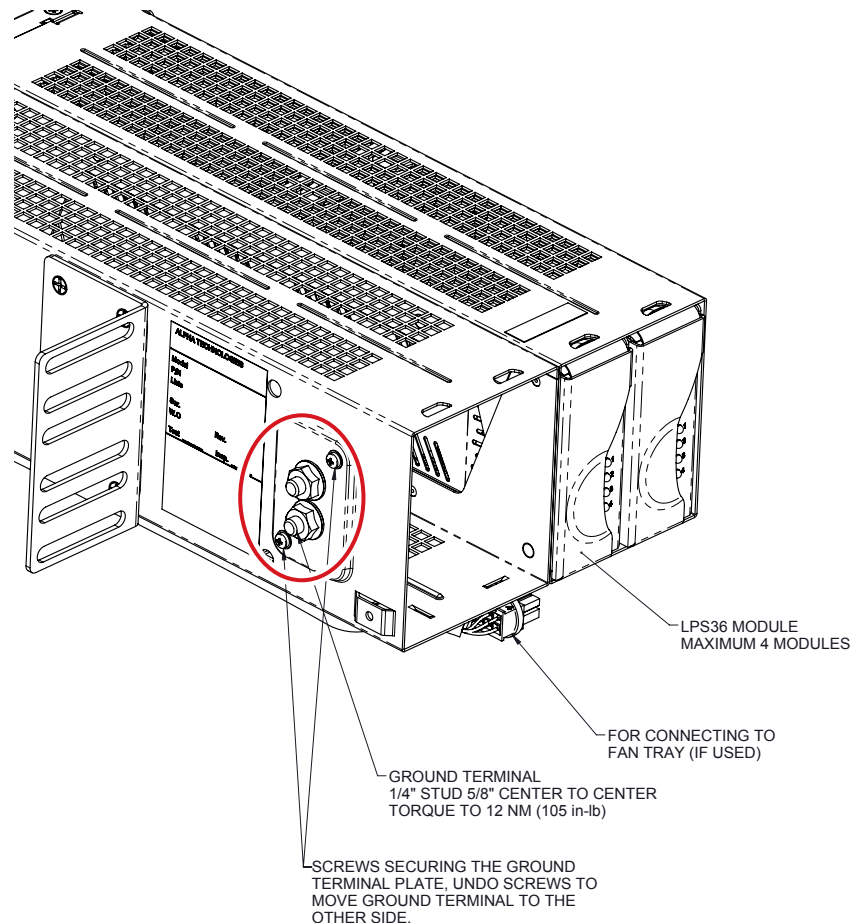

Figure 33 — Locations for Chassis Ground (LPS36 Compact, side view)

6.6.5 Connecting the DC Input

NOTE:
Connect the LPS36 Compact to a Safety Extra Low Voltage (SELV) <60VDC input power circuit.

Two #8 AWG wires with Anderson Power Connector SB50 are provided for input connections. A cable kit terminated with 2-hole lugs is available, PN 8700870-001.

Check wire labelling for connecting to proper polarity.

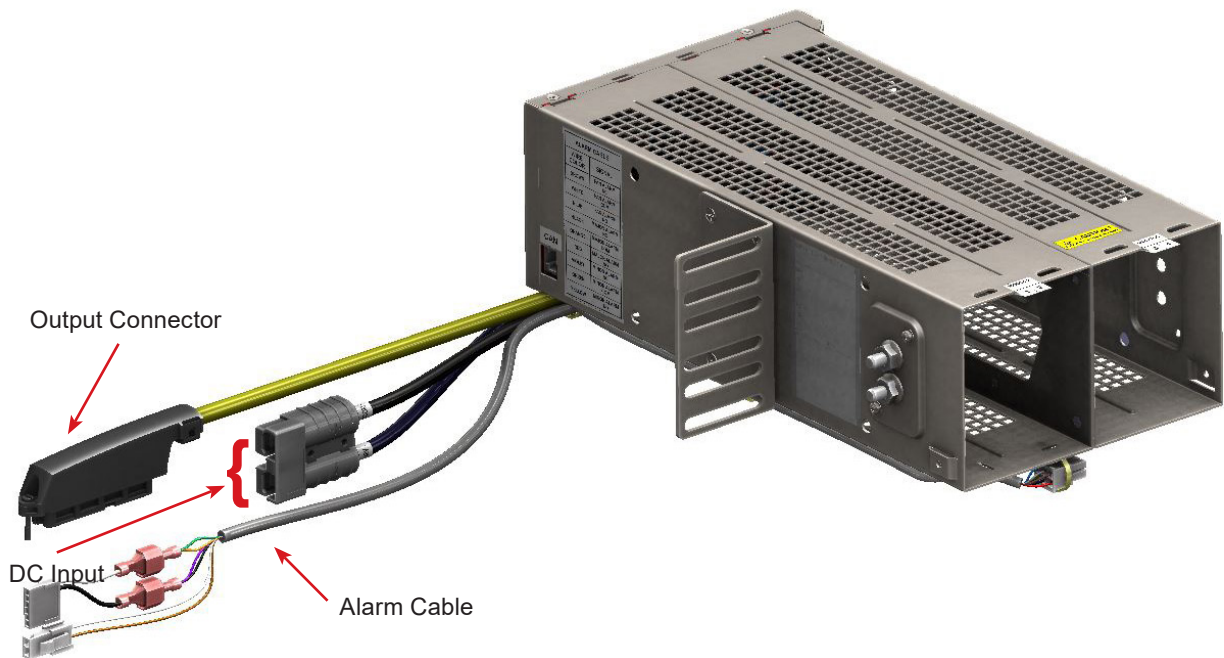

Figure 34 — DC Input Connections

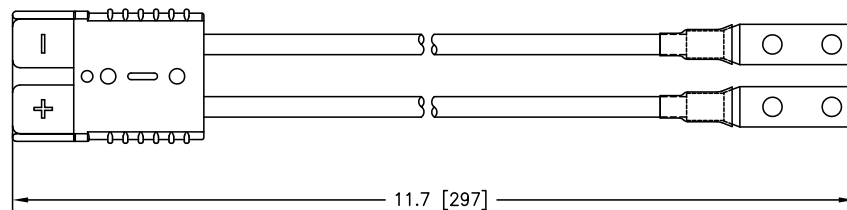

Figure 35 — DC Input Cable Kit Accessory

6.6.6 Alarm Cable Designation

Two Form C contacts are available for Major and Minor alarms for the LPS modules. If a fan tray is used, a separate Form C contact is also provided in case of fan failure. All these alarms are available via the alarm cable, refer to the PIN Assignment table in Figure 36.

ALARM CABLE	
WIRE COLOR	SIGNAL
BROWN	FAN ALARM NC
WHITE	FAN ALARM COM
BLUE	FAN ALARM NO
BLACK	MAJOR ALARM NC
ORANGE	MAJOR ALARM COM
RED	MAJOR ALARM NO
VIOLET	MINOR ALARM NC
GREEN	MINOR ALARM COM
YELLOW	MINOR ALARM NO

Figure 36 — PIN Assignment Table

6.6.7 Connecting Power to the Fan Tray

Power to the fans is provided by the converter shelf immediately above it. Plug the cable from the fan tray into the receptacle labeled FAN PWR in the converter shelf above it, see section 6.6.2.

6.6.8 Making CAN Connection

The shelf can be connected to an Alpha controller (CXCI+) via CAN. For CAN connection, refer to the drawings at the end of this manual (0300189-08).

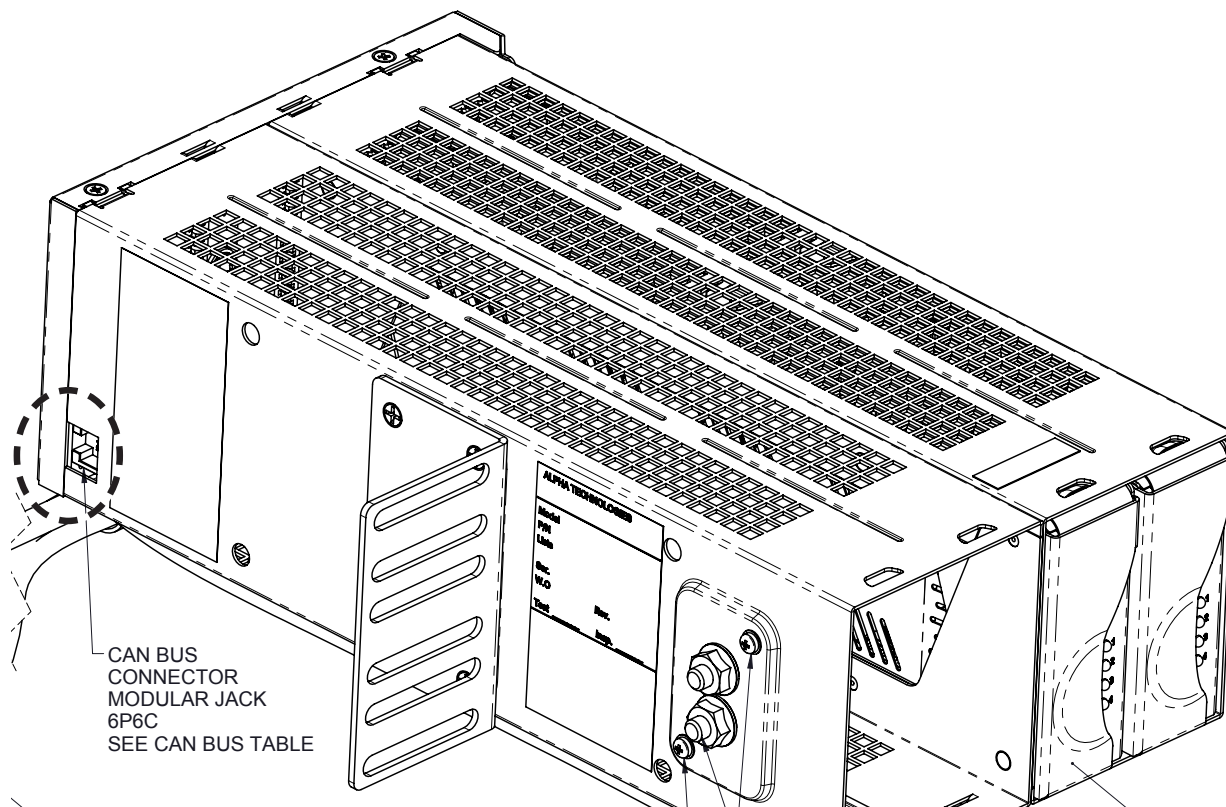

Figure 37 — CAN Connection

6.7 Making Load Connections

Connections to the loads are made with amp-champ style 50-pin connectors. (Figure 6 on page 18 shows connector locations.) Refer to Table C on page 42 for connector J1 pinouts and Table D on page 43 for connector J2 pinouts. The pinouts in these tables correspond to firmware version 1.03 or later.

Table C — Connector J1 Pinouts							
PIN POS	6" Shelf	19" Shelf	23" Shelf	PIN POS	6" Shelf	19" Shelf	23" Shelf
1	Conv1_Ch1-	Conv1_Ch1-	Conv1_Ch1-	26	Conv1_Ch1+	Conv1_Ch1+	Conv1_Ch1+
2	Conv1_Ch2-	Conv1_Ch2-	Conv1_Ch2-	27	Conv1_Ch2+	Conv1_Ch2+	Conv1_Ch2+
3	Conv1_Ch3-	Conv1_Ch3-	Conv1_Ch3-	28	Conv1_Ch3+	Conv1_Ch3+	Conv1_Ch3+
4	Conv1_Ch4-	Conv1_Ch4-	Conv1_Ch4-	29	Conv1_Ch4+	Conv1_Ch4+	Conv1_Ch4+
5	Conv2_Ch1-	Conv2_Ch1-	Conv2_Ch1-	30	Conv2_Ch1+	Conv2_Ch1+	Conv2_Ch1+
6	Conv2_Ch2-	Conv2_Ch2-	Conv2_Ch2-	31	Conv2_Ch2+	Conv2_Ch2+	Conv2_Ch2+
7	Conv2_Ch3-	Conv2_Ch3-	Conv2_Ch3-	32	Conv2_Ch3+	Conv2_Ch3+	Conv2_Ch3+
8	Conv2_Ch4-	Conv2_Ch4-	Conv2_Ch4-	33	Conv2_Ch4+	Conv2_Ch4+	Conv2_Ch4+
9	Conv3_Ch1-	Conv3_Ch1-	Conv3_Ch1-	34	Conv3_Ch1+	Conv3_Ch1+	Conv3_Ch1+
10	Conv3_Ch2-	Conv3_Ch2-	Conv3_Ch2-	35	Conv3_Ch2+	Conv3_Ch2+	Conv3_Ch2+
11	Conv3_Ch3-	Conv3_Ch3-	Conv3_Ch3-	36	Conv3_Ch3+	Conv3_Ch3+	Conv3_Ch3+
12	Conv3_Ch4-	Conv3_Ch4-	Conv3_Ch4-	37	Conv3_Ch4+	Conv3_Ch4+	Conv3_Ch4+
13	Conv4_Ch1-	Conv4_Ch1-	Conv4_Ch1-	38	Conv4_Ch1+	Conv4_Ch1+	Conv4_Ch1+
14	Conv4_Ch2-	Conv4_Ch2-	Conv4_Ch2-	39	Conv4_Ch2+	Conv4_Ch2+	Conv4_Ch2+
15	Conv4_Ch3-	Conv4_Ch3-	Conv4_Ch3-	40	Conv4_Ch3+	Conv4_Ch3+	Conv4_Ch3+
16	Conv4_Ch4-	Conv4_Ch4-	Conv4_Ch4-	41	Conv4_Ch4+	Conv4_Ch4+	Conv4_Ch4+
17	Empty	Conv5_Ch1-	Conv5_Ch1-	42	Empty	Conv5_Ch1+	Conv5_Ch1+
18	Empty	Conv5_Ch2-	Conv5_Ch2-	43	Empty	Conv5_Ch2+	Conv5_Ch2+
19	Empty	Conv5_Ch3-	Conv5_Ch3-	44	Empty	Conv5_Ch3+	Conv5_Ch3+
20	Empty	Conv5_Ch4-	Conv5_Ch4-	45	Empty	Conv5_Ch4+	Conv5_Ch4+
21	Empty	Empty	Conv6_Ch1-	46	Empty	Empty	Conv6_Ch1+
22	Empty	Empty	Conv6_Ch2-	47	Empty	Empty	Conv6_Ch2+
23	Empty	Empty	Conv6_Ch3-	48	Empty	Empty	Conv6_Ch3+
24	Empty	Empty	Conv6_Ch4-	49	Empty	Empty	Conv6_Ch4+
25	Empty	Empty	Empty	50	Empty	Empty	Empty

The part number for the mating connector is Tyco 5229912.

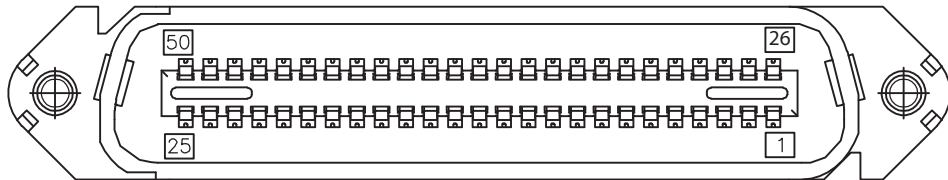

Figure 38 — Connector Pinouts

Table D — Connector J2 Pinouts (19" and 23" shelves only)

PIN POS	19" Shelf	23" Shelf	PIN POS	19" Shelf	23" Shelf
1	Conv6_Ch1-	Conv7_Ch1-	26	Conv6_Ch1+	Conv7_Ch1+
2	Conv6_Ch2-	Conv7_Ch2-	27	Conv6_Ch2+	Conv7_Ch2+
3	Conv6_Ch3-	Conv7_Ch3-	28	Conv6_Ch3+	Conv7_Ch3+
4	Conv6_Ch4-	Conv7_Ch4-	29	Conv6_Ch4+	Conv7_Ch4+
5	Conv7_Ch1-	Conv8_Ch1-	30	Conv7_Ch1+	Conv8_Ch1+
6	Conv7_Ch2-	Conv8_Ch2-	31	Conv7_Ch2+	Conv8_Ch2+
7	Conv7_Ch3-	Conv8_Ch3-	32	Conv7_Ch3+	Conv8_Ch3+
8	Conv7_Ch4-	Conv8_Ch4-	33	Conv7_Ch4+	Conv8_Ch4+
9	Conv8_Ch1-	Conv9_Ch1-	34	Conv8_Ch1+	Conv9_Ch1+
10	Conv8_Ch2-	Conv9_Ch2-	35	Conv8_Ch2+	Conv9_Ch2+
11	Conv8_Ch3-	Conv9_Ch3-	36	Conv8_Ch3+	Conv9_Ch3+
12	Conv8_Ch4-	Conv9_Ch4-	37	Conv8_Ch4+	Conv9_Ch4+
13	Conv9_Ch1-	Conv10_Ch1-	38	Conv9_Ch1+	Conv10_Ch1+
14	Conv9_Ch2-	Conv10_Ch2-	39	Conv9_Ch2+	Conv10_Ch2+
15	Conv9_Ch3-	Conv10_Ch3-	40	Conv9_Ch3+	Conv10_Ch3+
16	Conv9_Ch4-	Conv10_Ch4-	41	Conv9_Ch4+	Conv10_Ch4+
17	Empty	Conv11_Ch1-	42	Empty	Conv11_Ch1+
18	Empty	Conv11_Ch2-	43	Empty	Conv11_Ch2+
19	Empty	Conv11_Ch3-	44	Empty	Conv11_Ch3+
20	Empty	Conv11_Ch4-	45	Empty	Conv11_Ch4+
21	Empty	Conv12_Ch1-	46	Empty	Conv12_Ch1+
22	Empty	Conv12_Ch2-	47	Empty	Conv12_Ch2+
23	Empty	Conv12_Ch3-	48	Empty	Conv12_Ch3+
24	Empty	Conv12_Ch4-	49	Empty	Conv12_Ch4+
25	Empty	Empty	50	Empty	Empty

6.8 System Startup with CXCI+ Controller

To ensure proper operation, perform the following startup and test procedure after completing the system installation wiring.

6.8.1 Procedure

- Start with DC input breakers off.
- Install the CXCI+ into the leftmost position. (19"/23" shelf options only).
6" may be connected to a controller in a rectifier shelf via CAN (see section 6.6.8 on page 41).
- Install the converters in the slots.
- Turn on the DC breakers.

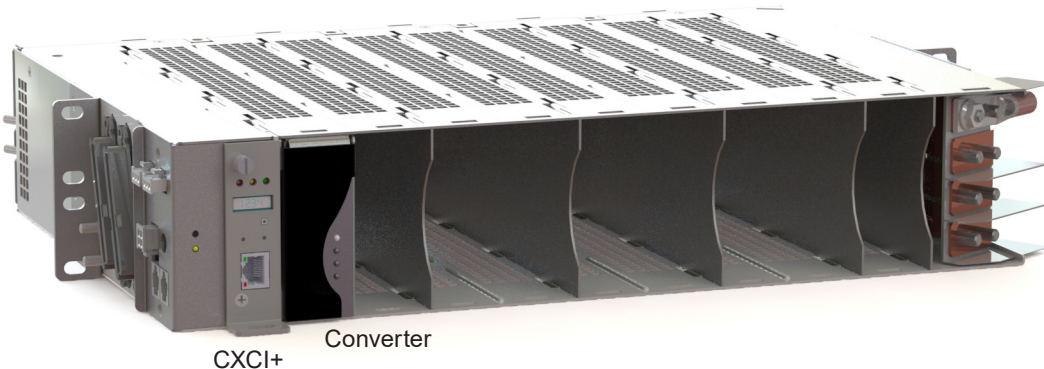

6.8.2 Parameter Setup

- Reset CXCI+ controller (front reset button) to set network IP parameters to factory default:
 - IP address: 10.10.10.201
 - Subnet mask: 255.255.255.0
- Connect a laptop to the controller with a network cable.
- Laptop IP Network settings (**Start > Control Panel**)
 - IP address: 10.10.10.202
 - Subnet mask: 255.255.255.0
- Turn off Pop-up Blocker.
- Enter: 10.10.10.201 in the web address bar. (Alpha recommends Internet Explorer with compatibility view turned on)
- Login to the controller:
 - User name: Enter your company name and your initials
 - Password: 1234
- Language selection: English
- Go to **Controller > Date & Time** to set correct date and time.
- Select **Line Powering System > View Live Status** to display a graphical view of all acquired LPS devices. Clicking an LPS module displays a pop-up window with information specific to that LPS module and its channels.
NOTE: If red text displays saying, “Invalid Shelf IDs have been detected!” or “Duplicate Shelf IDs have been detected!” the rotary dials to set shelf IDs have not be set up correctly.
- Log out.

6.8.3 Summary of Controller Software



NOTE:

Refer to the relevant user guide for controller functionality.

Menu item **Line Powering System > View Live Status** displays a graphical view of all acquired devices:

- Shelf ID
- Slot ID
- Per-channel information (output voltage and output current)

A tabular view can be accessed by clicking the **Switch to Table View** link. This can be useful if there are shelf ID conflicts which prevent the modules from showing in the graphical view.

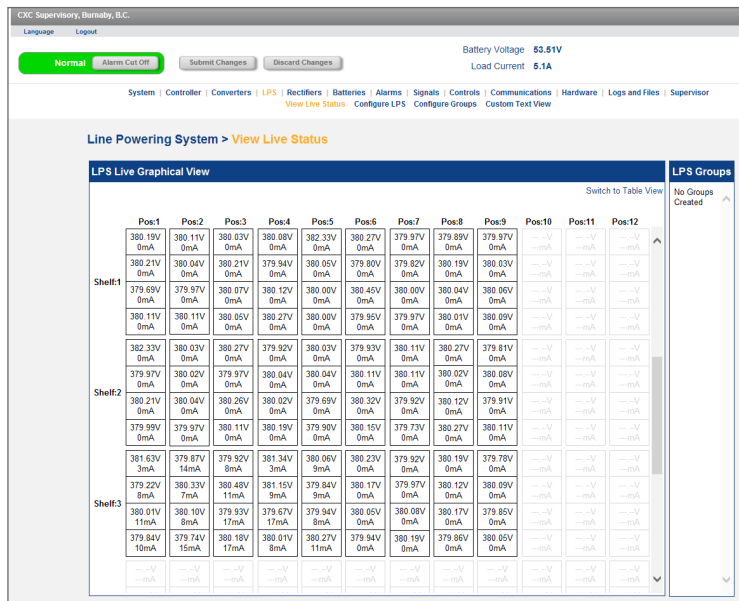

Figure 39 — Live Graphical View

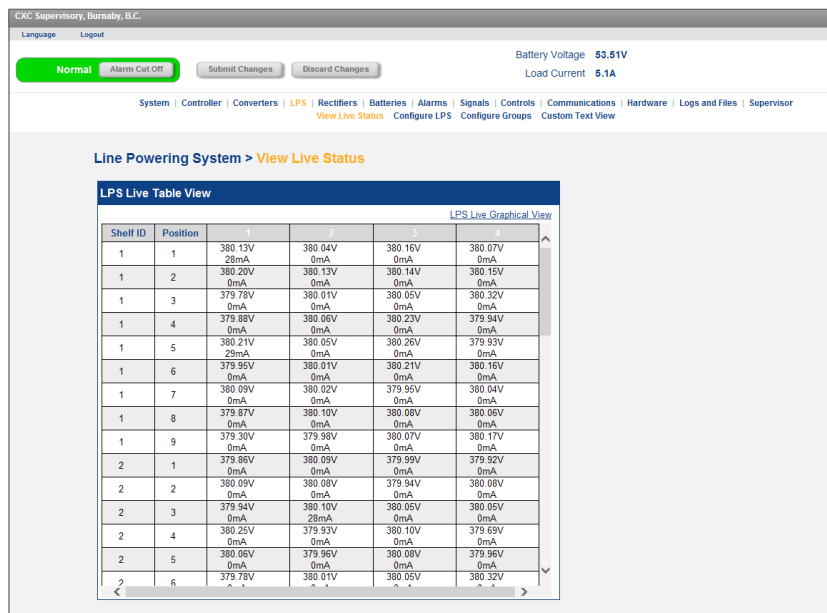

Figure 40 — Live Table View

Clicking a row displays a pop-up window with information specific to that LPS module and its channels.

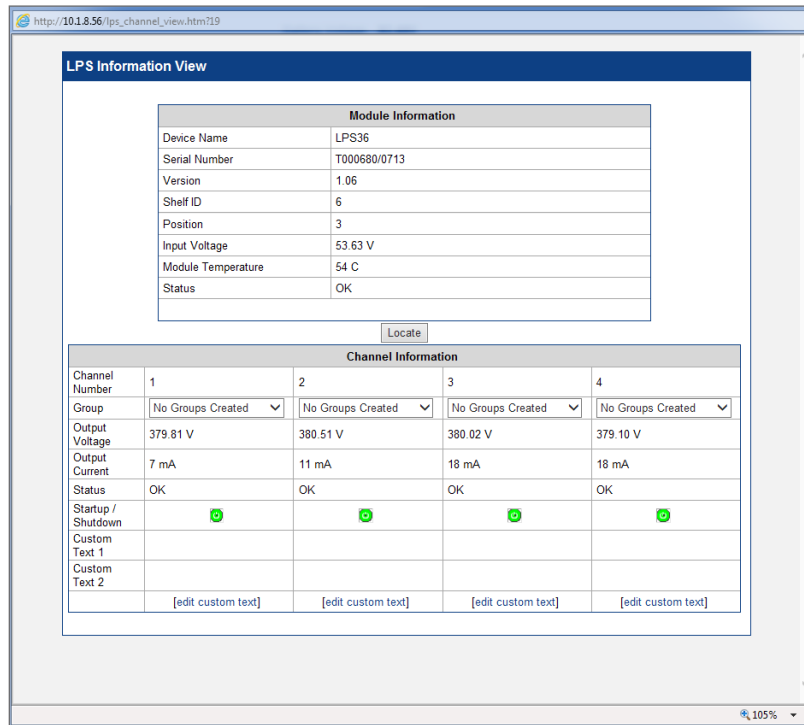

Figure 41 — Channel Information for Position 6

The icon in the **Startup/ Shutdown** row indicates whether the LPS channel is powered ON (green) or OFF (black). Clicking a green icon for a particular channel commands the module to turn the output of that channel OFF.



NOTE:

Note 1: If the LPS modules are swapped quickly after acquired by CXCI+ controller, the logical position in the GUI is not automatically updated to match the new slot position. To prevent this from happening, leave the LPS36 modules disconnected for long enough for the CXCI+ to detect they are missing (wait for the LPS Comms Lost alarm to be raised) before swapping them. In the event that the module position is not updated for any reason, an inventory update on the GUI or a soft reset on the CXCI+ will solve the issue.

Note 2: The remote Startup/Shutdown feature using CXCI+ controller is not a direct replacement for main power switch. This feature is mainly used to facilitate the reset of any latched channel, to temporarily enable/disable the channel, to synchronize restart of all group channels, or to clear any fault on the module. When the channel/module is in shutdown mode, cycling the input supply (by unplugging the module or by power removal) will make the channel/converter active again when power is restored.

6.8.4 LPS Channel Grouping

The CXCI+ has the capability of “grouping” LPS channels. This functionality is provided for the user’s convenience in displaying only, and does not correspond to any behavior on the modules themselves. It might be useful for users to set their grouping to match the “Group Reset” wiring that they have put into place on the back of the modules themselves.

On the **Line Powering System > Configure Groups** page, groups can be added, removed, and renamed. In addition, channels can be added to the groups by clicking the corresponding check boxes in the graphical view there. The group that a channel belongs to will be visible and editable from this page, and also on the module information pop-up page. In addition, the groups are displayed along the right-hand side of the page in the **Graphical Live View**.

If a user clicks on the group name, the channels belonging to this group will be highlighted on that page.

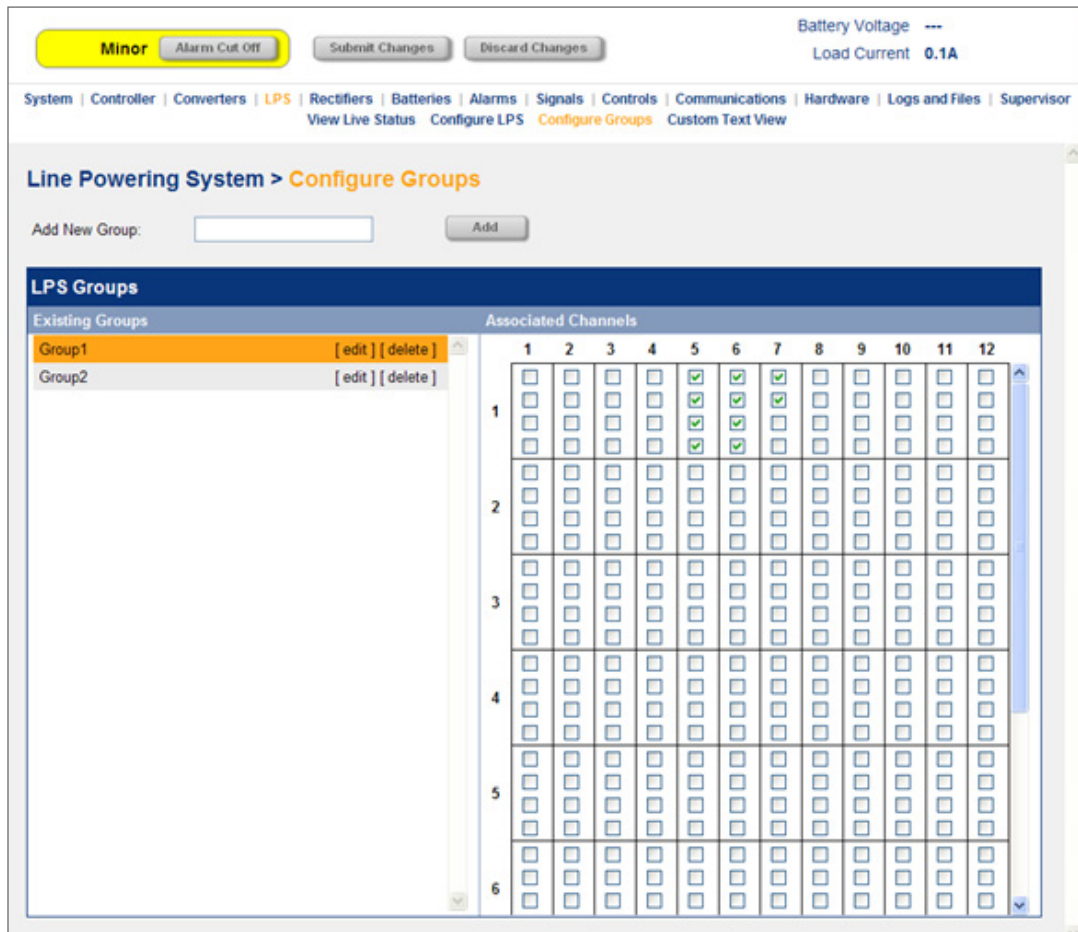

Figure 42 — Grouping LPS Channels

6.8.5 LPS Channel Custom Text

The CXC provides the user two custom text fields per LPS channel. These can be used to store information such as customer name or address where the channel output is directed, or any other information the user would like to associate with the channel.

The custom text can be viewed or edited from the module information page. In addition, there is a **Line Power System > Custom Text View** where the custom text and group information can be viewed all in one place. The groups and custom text can be edited on this page, and sorted to find all channels belonging to the same group, or with the same custom text.

Shelf	Position	Channel	Group	Custom Text 1	Custom Text 2	
1	1	1	Group2	Customer 1	4321 Riverfront Dr.	[edit]
1	1	2	Group2	Customer 1	4321 Riverfront Dr.	[edit]
1	1	3	Group2	Customer 1	4321 Riverfront Dr.	[edit]
1	1	4	Group2	Customer 1	4321 Riverfront Dr.	[edit]
1	2	1	Group1	Customer 2	85 Marine Dr.	[edit]
1	2	2	Group1	Customer 2	85 Marine Dr.	[edit]
1	2	3	Group1	Customer 2	85 Marine Dr.	[edit]
1	2	4	Group1	Customer 2	85 Marine Dr.	[edit]
1	3	1				[edit]
1	3	2				[edit]
1	3	3				[edit]
1	3	4				[edit]
1	4	1				[edit]

Figure 43 — LPS Channel Custom Text



NOTE:

Groups and the custom text are saved on the CXCI+ against the channel location (shelf ID, slot ID, and channel), not against the serial number of the unit itself. Therefore, if a unit is swapped or replaced, the information will still be saved against the same location.

LPS Alarms

The LPS and channel alarms are indicated on the **Line Powering System > View Live Status** interface with a red border (Figure 17).

LPS Live Status			
Shelf ID	Position	1	2
3	4	8.02V -22mA	377.35V 41mA
3	6	376.23V 13mA	376.97V 20mA
3	7	376.75V 21mA	376.46V 16mA
3	8	377.18V 39mA	376.34V 10mA

Figure 44 — LPS Alarm Highlighting

LPS alarms report in **Alarms > View Live Status** (Figure 45), **Alarms > Configure Alarms** (Figure 46 on page 50), and **Event Log** interfaces.

The CXC “rolls up” LPS alarm events. For example, if there are multiple LPS devices and one of them on one channel reports **Vout Low**, the alarm “LPS Channel Vout Low” is raised.

If a channel on a different LPS, also reports the same alarm, another distinct alarm will not be raised – it is “rolled up” into a single event.

Alarms > View Live Status

Major Alarms: 1 Minor Alarms: 6 Messages: 0 [Cleared Alarm History](#)

All Active Alarms		
Alarm Name	Priority	Status
Rectifier Fail	Minor	Active
Rectifier Minor	Minor	Active
Rect. Major Fail Count	Major	Active
Rect. Minor Fail Count	Minor	Active
LPS Single Output Failed	Minor	Active
LPS Channel Remote Shutdown	Minor	Active
LPS Channel Vout Low	Minor	Active

Figure 45 — Viewing LPS Alarms

Battery Voltage **54.00V**
Load Current **55.4A**

Normal
Alarm Cut Off
Submit Changes
Discard Changes

[System](#) | [Controller](#) | [Converters](#) | [LPS](#) | [Rectifiers](#) | [Batteries](#) | [Alarms](#) | [Signals](#) | [Controls](#) | [Communications](#) | [Hardware](#) | [Logs and Files](#) | [Supervisor](#)
[View Live Status](#) [Configure Alarms](#) [Global Alarm Configuration](#)

Alarms > Configure Alarms

Alarm Configuration LPS Alarms

Alarm Name	Activation Value	Enable	Priority	Relay Mapping	Alarm Cut Off	Email	SNMP	Severity
LPS Multiple Outputs Failed		<input checked="" type="checkbox"/>	Major	N/A	<input checked="" type="checkbox"/>	<input type="checkbox"/>	<input type="checkbox"/>	0
LPS Single Output Failed		<input checked="" type="checkbox"/>	Minor	N/A	<input checked="" type="checkbox"/>	<input type="checkbox"/>	<input type="checkbox"/>	0
LPS DC Input High		<input checked="" type="checkbox"/>	Minor	N/A	<input checked="" type="checkbox"/>	<input type="checkbox"/>	<input type="checkbox"/>	0
LPS DC Input Low		<input checked="" type="checkbox"/>	Minor	N/A	<input checked="" type="checkbox"/>	<input type="checkbox"/>	<input type="checkbox"/>	0
LPS Heatsink Temperature High		<input checked="" type="checkbox"/>	Minor	N/A	<input checked="" type="checkbox"/>	<input type="checkbox"/>	<input type="checkbox"/>	0
LPS Ambient Temperature High		<input checked="" type="checkbox"/>	Minor	N/A	<input checked="" type="checkbox"/>	<input type="checkbox"/>	<input type="checkbox"/>	0
LPS Fan Failure		<input checked="" type="checkbox"/>	Major	N/A	<input checked="" type="checkbox"/>	<input type="checkbox"/>	<input type="checkbox"/>	0
LPS Comms Lost		<input checked="" type="checkbox"/>	Minor	N/A	<input checked="" type="checkbox"/>	<input type="checkbox"/>	<input type="checkbox"/>	0
LPS Channel OVP		<input checked="" type="checkbox"/>	Minor	N/A	<input checked="" type="checkbox"/>	<input type="checkbox"/>	<input type="checkbox"/>	0
LPS Channel GFI		<input checked="" type="checkbox"/>	Minor	N/A	<input checked="" type="checkbox"/>	<input type="checkbox"/>	<input type="checkbox"/>	0
LPS Channel Fuse Alarm		<input checked="" type="checkbox"/>	Minor	N/A	<input checked="" type="checkbox"/>	<input type="checkbox"/>	<input type="checkbox"/>	0
LPS Channel Vout Low		<input checked="" type="checkbox"/>	Minor	N/A	<input checked="" type="checkbox"/>	<input type="checkbox"/>	<input type="checkbox"/>	0
LPS Channel OCP		<input checked="" type="checkbox"/>	Minor	N/A	<input checked="" type="checkbox"/>	<input type="checkbox"/>	<input type="checkbox"/>	0
LPS Channel Remote Shutdown		<input checked="" type="checkbox"/>	Minor	N/A	<input checked="" type="checkbox"/>	<input type="checkbox"/>	<input type="checkbox"/>	0

Figure 46 — Configuring LPS Alarms

Configuring a Fan Tray Alarm

When the fan tray is installed and connected to the CAN bus, it shows up as a signal in the **Signals > View Live Status** screen as shown in Figure 47. The signal is named **Fan Fail** so an alarm can be generated if any of the six fans fails. The steps in the next page show how to set up a custom alarm for the fan fail event.

Battery Voltage **51.19V**
Load Current **2.4A**

Major
Alarm Cut Off
Submit Changes
Discard Changes

[System](#) | [Controller](#) | [Converters](#) | [LPS](#) | [Rectifiers](#) | [Batteries](#) | [Alarms](#) | [Signals](#) | [Controls](#) | [Communications](#) | [Hardware](#) | [Logs and Files](#) | [Supervisor](#)
[View Live Status](#) [Configure Signals](#) [Configure Data Logging](#) [ADIO Device Configuration](#)

Signals > View Live Status

Signal List			
Signal Categories	Signals Name	Alarms	Value
Controller Signals	Fan Fail		1
Analog Input			
Digital Input			
Rectifier Signals			
Custom Signals			
Converter Signals			
Timers			
Counters			
Fan Tray			

Figure 47 — Fan Tray Live Status

To set up a **Custom Alarm**:

1. Select the menu item **Alarms > Configure Alarms** (Figure 48).
2. From the **Alarm Configuration** drop-down menu, select **Custom Alarms**.
3. Select the **Enable** check box of an unused custom alarm (**Custom 1**
4. From the **Priority** drop down menu, set the alarm **Priority** to **Major**.

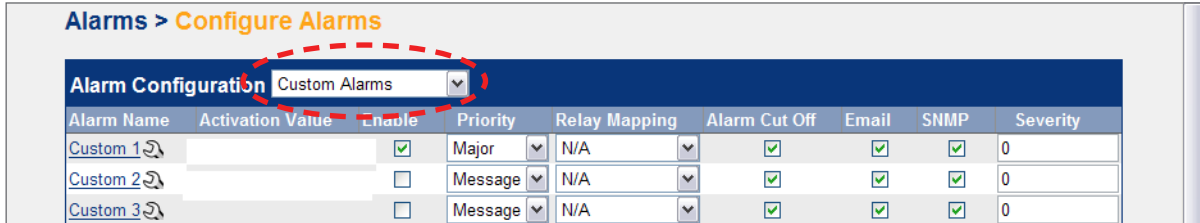

Figure 48 — Configuring a Custom Alarm

5. Click the **Custom 1** hyperlink to access the **Equation Editor**.
6. In the **Equation Editor**, select **Fan Tray, Fan Fail** and then click **Accept**.

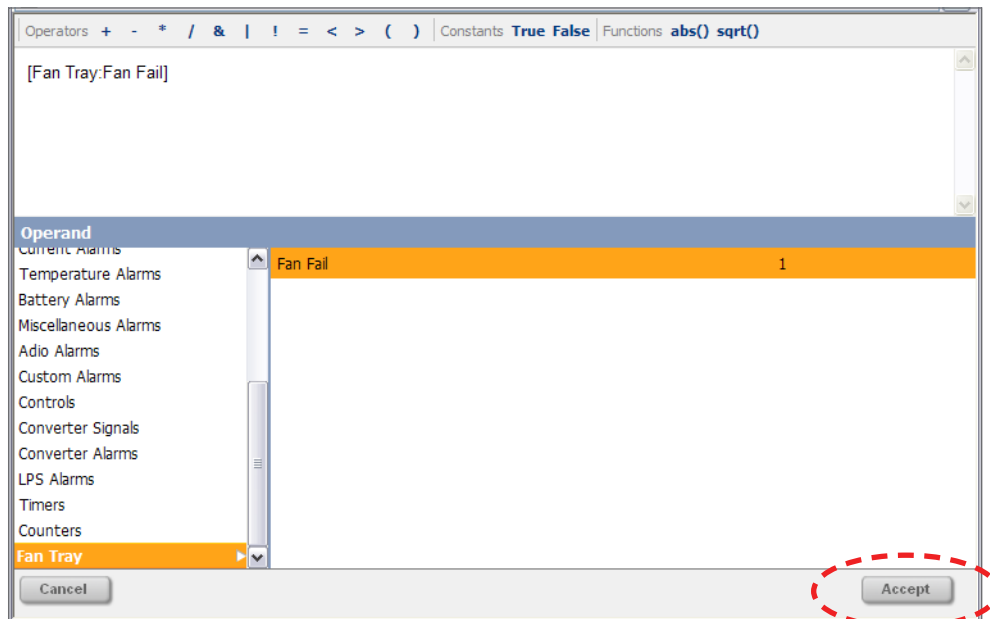

Figure 49 — Equation Editor for Configuring a Fan Fail Alarm

7. The **Alarms > Configure Alarms** screen reappears with the activation value now visible.
8. Click the **Submit Changes** button at the top of the screen.

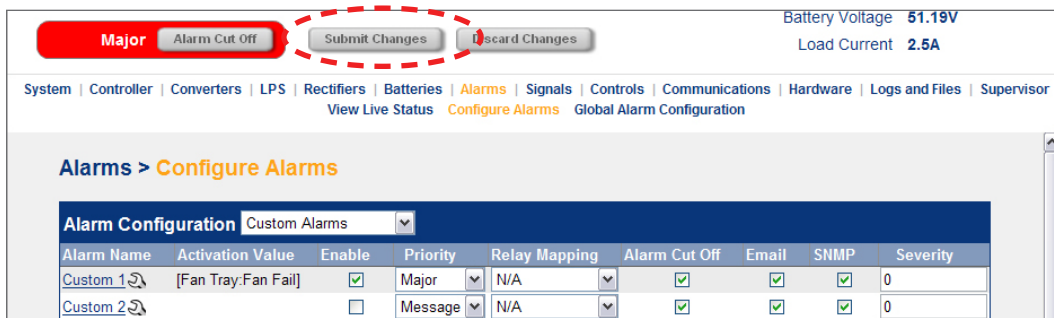

Figure 50 — Fan Fail Alarm

- Verify the changes on the pop up, and then **Accept** the Changes.
Change the name "Custom 1" to "Fan Fail".

- Click **Logs & Files > Manage Editable Text Files**.

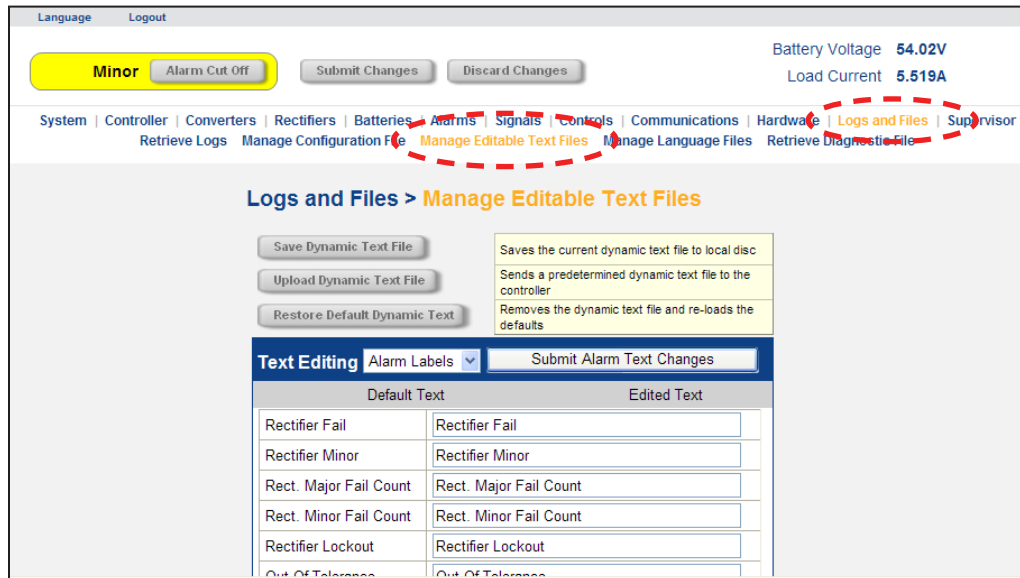

Figure 51 — Manage Editable Text Files

- Click in the text box for **Custom 1** and change the name to Fan Fail.

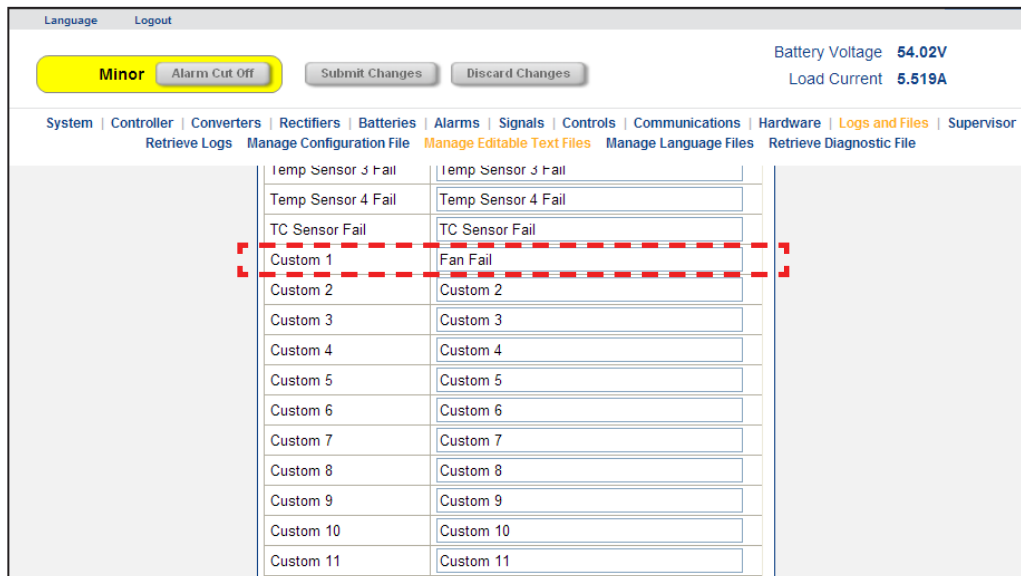
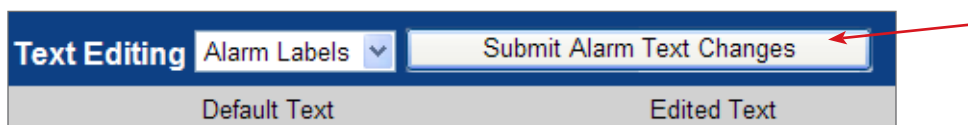

Figure 52 — Custom Name Change

- Click the **Submit Alarm Text Changes** button.



Controller Reset

Soft Reset

A soft reset enables the controller to finish saving files to flash memory before a power down or restart.

When pressed momentarily, the unit beeps twice then resets. The front-panel LEDs illuminate temporarily, but will extinguish after the system has finished its 15-second self-test.



CAUTION!

During reset, the controller may need to run a defragmentation cycle. Cycling of the LEDs on the controller front panel indicate that defragmentation is in progress. A full defragmentation can take up to 20 minutes to perform. DO NOT POWER DOWN the controller during this time.

IP Address Reset

This reset allows local access; for example, with a laptop and a standard network cable. To reset the IP address, press and hold the Soft/IP reset button for three seconds.

The CXCI+ beeps three times, the IP is reset to **10.10.10.201** and the DHCP is disabled. The settings are saved and the unit is reset.

Hard Reset

A hard reset button is also located on the front panel on the CXCI+, it is the unmarked button on the left front.

This reset button can be used to restart the microprocessor if the soft reset button fails.

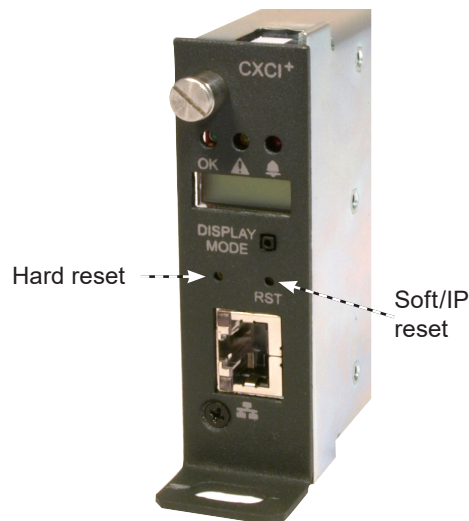

CAUTION!

Use of hard reset may cause loss of data.

6.9 System Startup with the CXCI HP Controller

To ensure proper operation, perform the following startup and test procedure after completing the system installation wiring.

6.9.1 Procedure with controller (19"/23")

- Start with DC input breakers off.
- Install the CXCI HP into the left-most position. (19"/23" shelf options only). The 6" may be connected to a controller in a rectifier shelf via CAN (see "6.6.8 Making CAN Connection" on page 40).
- Install the converters in the slots.
- Turn on the DC breakers.

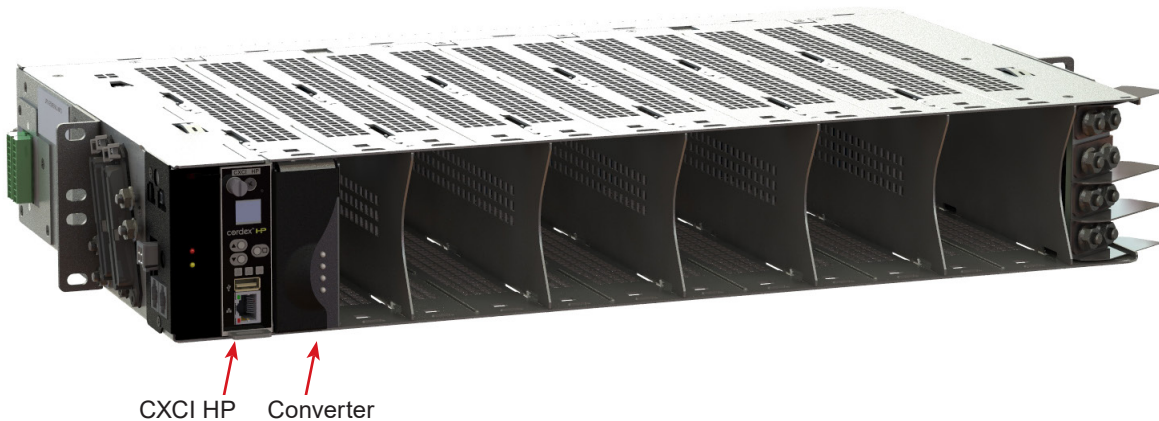

6.9.2 CXCI HP Controller Setup

- Set the network IP parameters to factory default.
IP address: 10.10.10.201
Subnet mask: 255.255.255.0
- Connect a laptop to the controller with a network cable.
- Laptop IP network settings (Start > Control Panel):
IP address; 10.10.10.202
Subnet mask: 255.255.255.0
- In the web address bar, enter 10.10.10.201.
- Login to the controller:
User name: admin
Password: admin
- Go to **Controller > Configure Controller > Date and Time** to set the correct date and time.

6.9.3 Creating a Line Power System

On a brand new controller, there is no existing line power system. You can create a new system from scratch or import one from a configuration file that contains a system from another controller. The current software release, only supports a single line power system per controller, which means that if a system already exists on the controller, the option to create a converter system will not be available.

A new power system can be created from the controller LCD or the web, via the **Controller > Inventory** or the **Modules > Unassigned Modules** menu. A wizard will help step you through the process to create the new system. The button to create a new system is only available if an LPS does not yet exist.

For detailed information on the controller go the Alpha website to download the software manual.

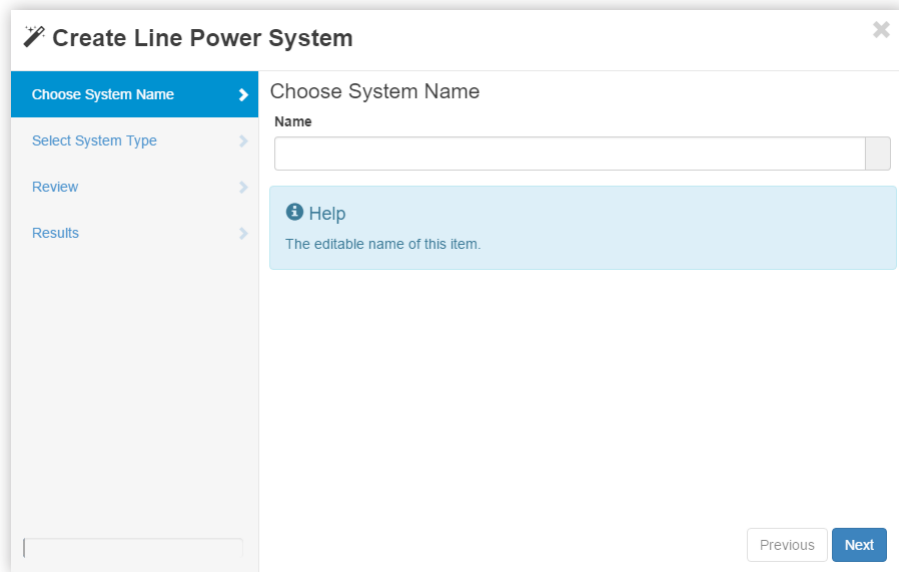

Figure 53 — Line Power System Wizard

6.9.4 Configuring a Line Power System

Quick Reference Map: Configuring a Line Power System

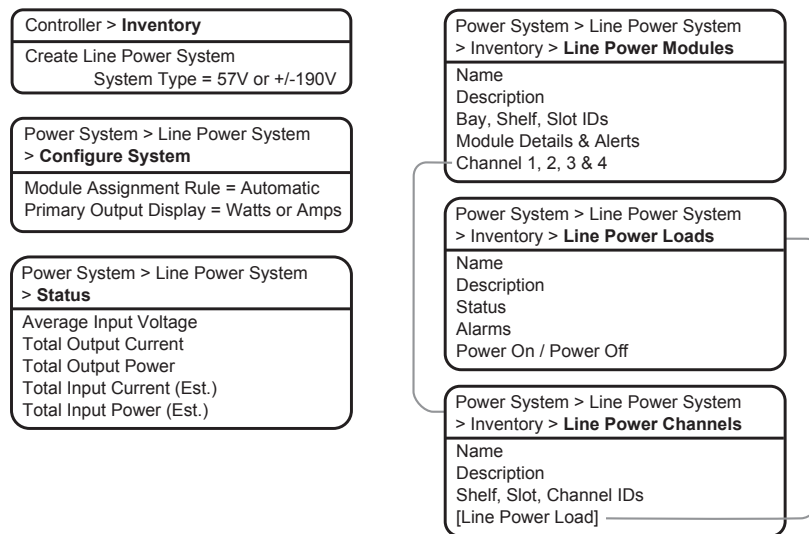

Figure 54 — Quick Reference: Configure a Line Power System

The new system will have a reasonable set of defaults and associated alarms where possible. Optional configurable values, such as name, description, system number, can be used to describe and organize your system.

The **Module Assignment Rule** setting controls how newly discovered LP modules are treated. The two options are **Manual** and **Automatic**. The **Manual** setting, groups all new LP modules into **Unassigned Modules**. Then you can add them to the system manually. Selecting **Automatic** adds new, compatible LP modules to the system automatically. This is usually the preferred setting.

You can configure the alarms associated with the LP system. You can enable or disable the alarms, change the priority, map relays to the alarms, and where applicable, modify the thresholds.

To create a Line Power System:

1. Go to **Controller > Inventory**.
2. Click **Create Line Power System**. Name the system if required.
3. From the **Select System Type** drop down, select the value that corresponds to your LPS module type. If there are modules already connected to the controller, this will be preselected with the correct option.
4. Follow the rest of the wizard instructions.

6.9.5 Configure the Line Power Modules

There are two settings that are applied to all LPS modules: **Input Voltage Low Shutdown** and **Input Voltage Low Restart**.

When the input voltage falls below the low shutdown threshold, the LP modules will power off all output channels. Set this threshold to a value that prevents over-discharge of the battery.

When the input voltage rises above the restart threshold, the units turn back on. The restart threshold must be at least two volts above the shutdown threshold or the LP Module Configuration Error alarm will activate (LPS36 only).

These settings are stored on the LP module itself which means that even if disconnected from the controller the LP modules will still perform in this way.

To configure the LP modules:

1. Go to **Power Systems > Line Power System > Configure System**.
2. From the **Configuration** table, set the **Input Voltage Low Shutdown** threshold to the desired value.

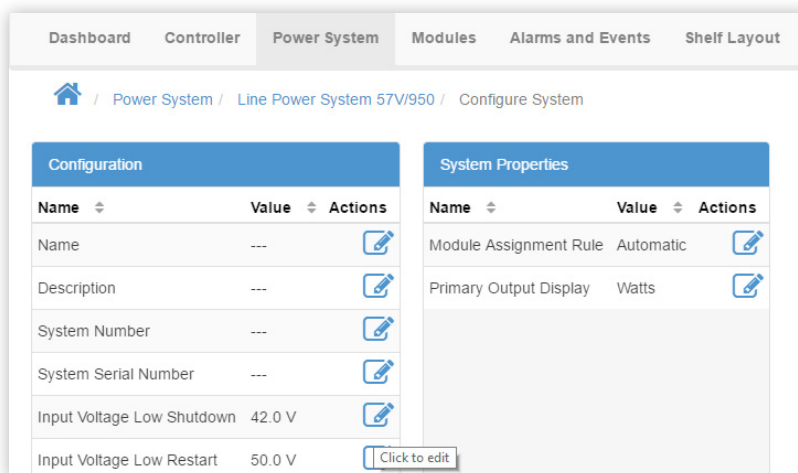

3. In the same table, set the **Input Voltage Low Restart** threshold to the desired value.

6.9.6 Configure Line Power Channels

Each LP module has four channels that can be given a name, description and assigned to a load. All channels are listed in table that can be sorted and searched. You can also export all channel details to a file.

To configure the channels:

1. Go to **Power System > Line Power System > Inventory > Line Power Channels**. You will see a table of channels in the system. There is also a **Export Channel Details** button to export the information to a .csv file.
2. Channels cannot be added or removed. It is also possible to configure channels and get detailed channel information from **Power System > Line Power System > Inventory > Line Power Modules** and clicking the more details icon for the module.
3. Click the more details icon for the channel you want to configure.
4. In the channel table, assign an optional name and description. This might be a channel address, wire color or customer name.
5. In the channel table, assign an optional **Line Power Load**. To assign a load it is necessary to first create a load. Refer to section 6.9.7 to do this.

6.9.7 Configure the Line Power Loads

A line power load represents the remote load that is powered by the LP module channels. Create a load when you want to monitor and alarm separate remote loads. Creating a load allows all channels that have been assigned to the load to be powered on or off as a group. To turn all the channels assigned to a load on or off, use the **Power On** or **Power Off** buttons on the **Configuration** table.

You may add or remove loads as needed. Removing a load does not affect the power delivered.

Note: To assign channels to a load, refer to the section on **LPS Layout** or **Configure Line Power Channels**.

To configure the loads:

1. Go to **Power Systems > Line Power System > Inventory > Line Power Loads**. You will see a table for loads in the system. This table shows how many channels are assigned to the load and the loads total output current and power. Add or remove loads from this screen.
2. Click the more details icon for the load you want to configure.
3. In the **Configuration** table, assign the load a name and a description. Alpha recommends that you assign the load a name that represents the actual load.
4. Configure the load alarms as needed.

6.9.8 Line Power System Layout

The line power system **Layout** screen shows a graphical view based on the shelf and slot ID as reported by the line power modules. This view allows a convenient way to view module status and to configure and interact with individual channels.

Using the Layout Screen to View Module Status

The line power Layout screen provides a convenient way to find the following status information:

- Module shelf and slot position
- Output voltage, power and current for each module
- Module and channel alert status
- Module and channel information (detailed)

The following steps describe how to use the Layout screen to view module and channel status:

1. Go to **Power Systems > Line Power System > Layout**. This screen shows a grid of LP modules organized by shelf ID vertically, and slot ID horizontally. Each module is represented by a rectangle showing the output voltage and the output power for each channel. The information in the rectangle is green to indicate that a module is operating normally.

It is possible to display channel output power or channel output current on this screen. Change the **Primary Output Display** to the desired value in the **System Properties** table at **Power Systems > Line Power System > Configure System**.

2. Select a channel for detailed information. If a module has an active alert then the green turns to red to indicate an alert with the module or with a channel. If the alert is on a specific channel then the specific channel will be highlighted red. If it is module alert only, then the channels will all show green but there will be red border around the module. To get more detail on the active alert, select the channel that has the alert (if it is a module alert select any channel that belongs to the module. This shows a new table with channel details.
3. In the **Channel Details** table, click the more details icon for the **Line Power Module** to view active alert information.
4. In the **Module Alerts** table sort by **Value** to bring the active alerts to the top of the table.

6.9.9 Using Screen Layout to Assign Channels to Loads

The line power Layout screen provides a convenient way to:

- View which channels have been assigned to the LP Loads
- Assign channels to LP Load
- Unassign channels from Loads

The following steps describe how to use the Layout screen to view and configure channels assigned to LP Loads:

1. Navigate to **Power Systems > Line Power System > Layout**. At the top of the table notice that there is a drop down box to choose one of the LP loads. If no load have been created, navigate to **Power Systems > Line Power System > Inventory > Line Power Loads** and create one now.
2. Select a load in the drop down box. The channels assigned to this load will appear highlighted as shown below.

Shelf	Slot 1	Slot 2	Slot 3	Slot 4	Slot 5	Slot 6	Slot 7	Slot 8	Slot 9
1	C1 380.0 V 3.4 W	C1 380.1 V 0.0 W	C1 380.0 V 0.0 W	C1 380.0 V 0.0 W	C1 380.2 V 0.0 W	C1 380.0 V 0.0 W	C1 380.3 V 0.0 W	C1 380.1 V 0.0 W	C1 380.0 V 0.0 W
	C2 380.4 V 3.0 W	C2 379.9 V 0.0 W	C2 379.9 V 0.0 W	C2 380.0 V 0.0 W	C2 380.1 V 0.0 W	C2 379.9 V 0.0 W	C2 380.0 V 0.0 W	C2 379.8 V 0.0 W	C2 380.1 V 0.0 W
	C3 380.0 V 0.0 W	C3 380.0 V 0.0 W	C3 380.1 V 0.0 W	C3 380.0 V 0.0 W	C3 380.2 V 0.0 W	C3 380.1 V 0.0 W	C3 380.3 V 0.0 W	C3 380.3 V 0.0 W	C3 379.8 V 0.0 W
	C4 380.1 V 0.0 W	C4 380.0 V 0.0 W	C4 380.1 V 0.0 W	C4 380.1 V 0.0 W	C4 379.9 V 0.0 W	C4 379.9 V 0.0 W	C4 380.4 V 0.0 W	C4 380.0 V 0.0 W	C4 357.8 V 0.0 W

3. To add a new channel to the load, select it. The channel rectangle will turn blue to indicate it is selected.

Shelf	Slot 1	Slot 2	Slot 3	Slot 4	Slot 5	Slot 6	Slot 7	Slot 8	Slot 9
1	C1 380.1 V 3.4 W	C1 380.0 V 0.0 W	C1 380.3 V 0.0 W	C1 380.1 V 0.0 W	C1 380.0 V 0.0 W	C1 380.1 V 0.0 W	C1 379.9 V 0.0 W	C1 357.9 V 0.0 W	C1 380.0 V 0.0 W
	C2 380.2 V 3.0 W	C2 380.2 V 0.0 W	C2 380.1 V 0.0 W	C2 379.8 V 0.0 W	C2 0.0 V 0.0 W	C2 380.0 V 0.0 W	C2 379.4 V 0.0 W	C2 358.0 V 0.0 W	C2 380.0 V 0.0 W
	C3 380.0 V 0.0 W	C3 380.1 V 0.0 W	C3 380.1 V 0.0 W	C3 379.8 V 0.0 W	C3 380.0 V 0.0 W	C3 380.1 V 0.0 W	C3 380.0 V 0.0 W	C3 357.9 V 0.0 W	C3 380.4 V 0.0 W
	C4 380.0 V 0.0 W	C4 380.0 V 0.0 W	C4 379.9 V 0.0 W	C4 380.1 V 0.0 W	C4 0.0 V 0.0 W	C4 379.8 V 0.0 W	C4 380.3 V 0.0 W	C4 358.0 V 0.0 W	C4 380.0 V 0.0 W

Name	Value	Actions
Enabled	False	
C2 Output Voltage	0.0 V	
C2 Output Current	0.000 A	
C2 Output Power	0.0 W	
C2 Number of Alerts	1	
Name	---	
Description	---	
Line Power Load	---	
Line Power Module	390000338/0913	

The screenshot shows the 'Bay 1' interface. At the top, there are buttons for 'Assign Selected Channel(s) to Selected Load', 'Unassign Selected Channel(s) from Load', and '+ Add Line Power Load'. Below these is a 'Line Power Load' dropdown menu currently set to '(None)'. A 'Locate' button is also visible. The main area is a grid of power channels. The 'Line Power Load' details panel on the right shows the following information:

Name	Value	Actions
Enabled	False	
C2 Output Voltage	0.0 V	
C2 Output Current	0.000 A	
C2 Output Power	0.0 W	
C2 Number of Alerts	1	
Name	---	
Description	---	
Line Power Load	---	
Line Power Module	390000338/0913	

- In the channel details table, click the **Assign** button. This will assign the channel to the load. The **Assign** button will become disabled and the **Unassign** button will become enabled. In the channel details table, the **Line Power Load** field will be populated with the name of the load.
- By default, the **Assign** and **Unassign** buttons are disabled unless a load is selected.

The screenshot shows the 'Bay 1' interface with the 'Unassign Selected Channel(s) from Load' button highlighted by a mouse cursor. The 'Line Power Load' dropdown menu is now set to 'LP Load (8220)'. The grid of power channels is visible, with the 'Unassign' button being the focus of the action.

- To unassign a channel from the selected load, click on a highlighted channel and click the **Unassign** button. This will unassign the channel from the load. The **Assign** button will become enabled and the **Unassign** button will become disabled. In the channel details table, the **Line Power Load** field will be set to "--"

NOTE: Highlighting a specific channel and then pressing the Locate button, enables you to locate the physical LPS module associated with that specific channel.

Once pressed, the LEDs on the selected module cycle briefly for easy identification.

6.9.10 Powering Off and On Line Power Loads

A line power load usually has multiple channels from different modules assigned to it. It may be necessary to occasionally power off, then power on the load.

To power off or on a load:

1. Go to Power Systems > Line Power System > Inventory > Line Power Loads and click on the details icon for the load to be powered off.
2. In the Status table, verify that the Channels value is at least 1. The Power On/Off buttons will only work if there are one or more channels assigned to the load.
3. In the Configuration table, click the Power Off button. After a few moments the Channels Enabled, Total Output Current and Total Output Power values in the Status table will go to zero. This indicates that the load has been turned off. The Power Off button will become disabled and the Power On button becomes enabled.
4. To turn on the load, press the Power On button alarm.

6.9.11 Powering Down the Controller

Sometimes it may be necessary to power down the controller to replace, remove or repair rectifiers.



CAUTION!

You must use the LCD or web interface to reset the controller. This ensures that recent changes and files are saved properly.

1. From the main dashboard, go to **Controller > Controller Status** and then click controller reset.
2. From the LCD screen go to **Menu > Controller > Controller Status > Reset Controller**.
3. While the controller LEDs are cycling, power down the controller by removing the power pin on the right-side of the controller.

7. Maintenance and Troubleshooting

Although very little maintenance is required with Alpha systems, routine checks and adjustments are recommended to ensure optimum system performance. Qualified service personnel should do the repairs.



WARNING!

Use extreme care when working inside the unit while the system is energized. Do not make contact with live components or parts.



Circuit cards, including RAM chips, can be damaged by static electricity. Always wear a grounded wrist strap when handling or installing circuit cards.

Ensure redundant modules or batteries are used to eliminate the threat of service interruptions while performing maintenance on the system's alarms and control settings.

The following table lists a few maintenance procedures for this system. These procedures should be performed at least once a year.

Procedure	Date Completed
Clean ventilation openings.	
Inspect all system connections. Re-torque if necessary.	
Verify alarm/control settings.	
Verify alarm relay operation.	

7.1 Troubleshooting Converter Status LEDs

7.1.1 Card Alarms (All 4 LEDs)

LED State	Individual Converter status	Action
Green	Normal	None
Blinking Green	Shelf is not compatible with the module	Ensure that the shelf is correct. Note: Slots for the eLimiter+ and LPS36 shelves are mechanically identical and the modules can be interchanged.
	Module not seated properly	Re-seat module
Yellow	Recoverable: • Ambient temperature high	Resets automatically when ambient temperature reduces to approximately 85°C or below.
Blinking Yellow	Input quality not OK	Output is disabled if input voltage is not within the range of 40-60Vdc.
OFF	Recoverable: • No power	Check input wiring.
	Non-recoverable: • Main input fuse cut-off	Potential component failure. Replace with new module.
Chasing Red/Green Pattern	Locate feature enabled	None

7.1.2 Individual Channel Alarms

LED State	Individual Converter Status	Action
Green	Normal	None
Blinking Green	Remote shutdown enabled on individual channel/converter	Can be reset by toggling Startup / Shutdown button through the CXCI+ controller.
Blinking Yellow	Recoverable: <ul style="list-style-type: none"> • OCP/Overload • Vout low 	Ensure the load is within rated current. Check that output is within the regulation range.
	Non-recoverable: <ul style="list-style-type: none"> • Converter input fuse fail 	Potential component failure. Replace with new module.
Red	Recoverable: <ul style="list-style-type: none"> • OVP 	OVP will cause the output to restart every two seconds until the fault is removed. If the fault persists for 60 seconds, the output will shutdown for 60 seconds and attempt a restart every 60 seconds until the fault is cleared.
	Non-recoverable: <ul style="list-style-type: none"> • Converter output fuse fail 	Failed fuses are not field replaceable. Replace with new module.
Blinking Red	Recoverable: <ul style="list-style-type: none"> • GFI 	If the fault persists for 60 seconds the output will shutdown for 30 seconds and attempt to restart every 30 seconds until the fault is cleared.

7.1.3 Troubleshooting the Fan Tray Status LED

LED State	Module Status	Action	Shelf Size
Green	Normal	None	6", 19", 23"
Blinking Green	Ambient temperature <20°C	None	19", 23"
Yellow	Recoverable: <ul style="list-style-type: none"> • Ambient temperature high 	Resets automatically when ambient temperature reduces to approximately 85°C or below.	19", 23"
Blinking Yellow	Recoverable: <ul style="list-style-type: none"> • Input voltage out of range (high/low) 	Fan operation is disabled if input voltage is not within the range of 40-60Vdc.	19", 23"
	Non-recoverable: <ul style="list-style-type: none"> • Fan voltage low 	Possible component failure. Replace fan tray.	19", 23"
Red	Fan fail	Replace fan tray.	6", 19", 23"

7.2 Fan Filter Maintenance and Installation (19/23" only)

Alpha LPS36 Fan Filter use Universal's Quadrafoam™ permanent cleanable filter. The filter needs to be regularly cleaned to remove accumulated dust and debris. The maintenance interval should be set for every 90 days - to be cleaned or replaced.

7.2.1 Regular Filter Cleaning Procedure

1. Remove the LPS36 Fan Filter from the Fan Tray. Clean the filter material as follows:
 - Vacuum Clean - A few passes of a vacuum cleaner will remove accumulated dust and dirt in seconds.
or
 - Blow with compressed air - point compressed air nozzle in opposite direction of operating air flow (blow from exhaust side toward intake side).
2. If dirt persist on the filter after vacuuming or blowing air, it is recommended to proceed with washing:
 - Cold water rinse. Contamination is washed away quickly and easily using just a standard hose nozzle with tap water.
or
 - Immerse in warm, soapy water - where stubborn air-borne dirt is present, the filter may be dipped in a solution of warm water and mild detergent. Then simply rinse in clear water, let stand until completely dry and free of moisture before returning to normal operation.
3. If the filter still retains visible contamination, it is recommend to replace the LPS36 Fan Filter with a new one.
4. Follow the LPS36 Fan Filter Installation steps in the following section to return to service the cleaned or replacement new Fan Filter.

7.2.2 LPS36 Fan Filter Installation Procedure

Use the following steps to install the fan filter in the Alpha LPS36.

1. Make sure the baffle is installed at the bottom of fan tray (19 inch version shown).
2. Visually align the tabs to the slots so that the filter is covering all slots and angle them less than 30-45° as per blue angle lines (in step 5).



3. It is recommended to align a filter tab to the 4th baffle slot from the left.



4. Align a filter tab to 3rd baffle slot from the right.

5. Angle the filter at 30-45° for visual alignment and then hinge towards the top. Softly push downwards when

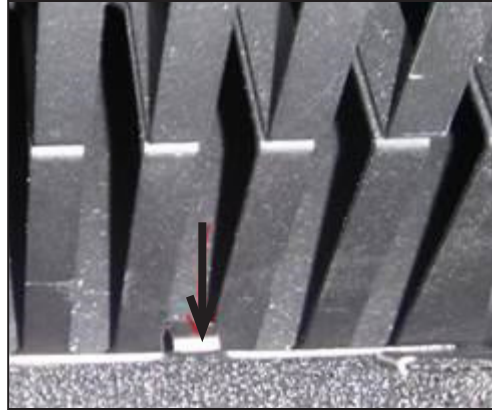

the filter frame is at approximately 10° to the front face of the fan tray.

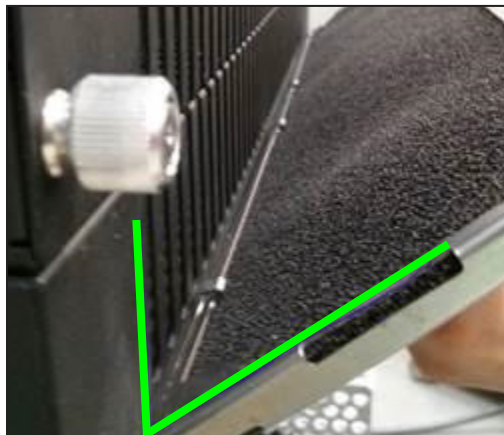

6. Affix the filter by allowing the top right and left corners to magnetically attach to the fan tray.



Installed fan tray should look like the following image.



7.3 Replacing the Fan Tray

NOTE:

The recommended maintenance interval for a fan tray is 6-years at 30°C. Individual fans are not replaceable. The fan tray is replaced as a single unit.

7.3.1 Fan Tray Replacement 19"/23" Shelves

1. Unplug power cable and remove signal wiring, if applicable.
2. Loosen the two front panel screws and slide assembly forward to remove. Replace with new assembly.
3. Re-plug power cable and attach signal wiring if applicable.

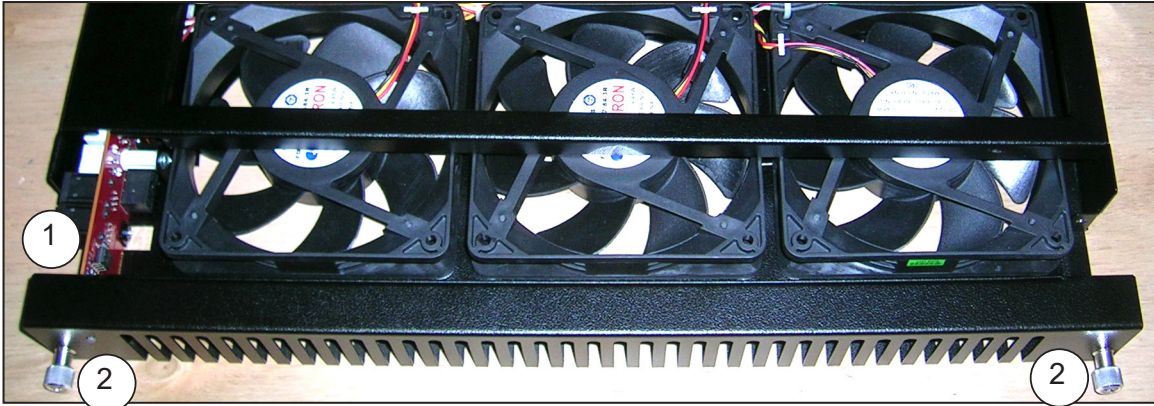

7.3.2 Fan Tray Replacement 6" Shelves

1. Disconnect the fan connector.
2. Loosen the two thumb screws securing the fan tray.
3. Drop down the front of the fan tray, remove fan wire and grommet from the slot.
4. Pull the fan tray out to the front gently and remove from the shelf.
5. Slide the back side of the fan tray to the cradle at an angle.
6. Insert the wire grommet back to the slot with fan wire, and then move the fan tray front into position so that the two thumb screws can be engaged and tightened.
7. Plug the fan connector to the fan tray.

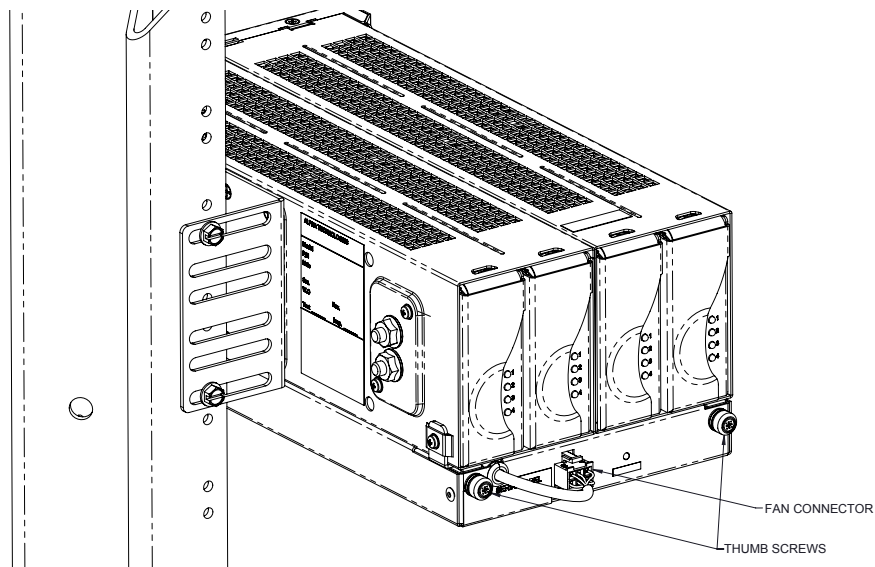

7.4 Replacing a Converter (19"/23")

The LPS36 converter modules are plug and play. When a converter module is added to the system, the controller will detect and update the inventory automatically.

Replacing an installed converter requires a manual **Inventory Update** from the controller web interface to clear the removed converter from its current list of rectifiers.

1. Connect a laptop to the controller with a network cable.
2. Laptop IP Network settings (**Start > Control Panel**)
 - IP address: 10.10.10.202
 - Subnet mask:255.255.255.0
3. Turn off Pop-up Blocker.
4. 10.10.10.201 in the web address bar.
5. Login to the controller:
 - User name: Enter your company name and your initials
 - Password: 1234
6. Go to **Main Menu > Rectifiers > Inventory Update**.

7.5 Replacing the Controller (19"/23" only)

1. Undo the locking screw on the front of the controller until it clears the locking mechanism.
2. Slide the locking mechanism on the interface board towards the unlock symbol.
3. Remove the controller.



7.6 Replacing an Alarm Relay Module (19"/23" only)

The following two procedures cover how to replace an alarm relay for shelves with or without the CXCI+ controller. The system is operational even without the controller during the alarm relay interface board change.

1. Remove the controller using the steps for 'Replacing the Controller' in section .7.4.
2. Leave the locking tab in the 'unlock' position (pushed all the way to the left).



3. Unwind the 2 screws shown in a counterclockwise direction, using a stubby Phillips driver. ATTENTION!! Keep the screws for the replacement kit.
4. Remove the two screws and then slowly slide the entire interface bracket out for about 2 inches. At this distance, the ribbon cable (not shown) should still maintain some slack.



- Carefully disconnect the female end of the 20-pin ribbon cable from the male end socket (shown below). The 20-pin connectors are directional, so you can only place it in one way due to the notch on the male-end and tab design on the female end.

Outlined is part of the fan tray power cable (for reference) it may or may not to be connected depending on the required system setup .

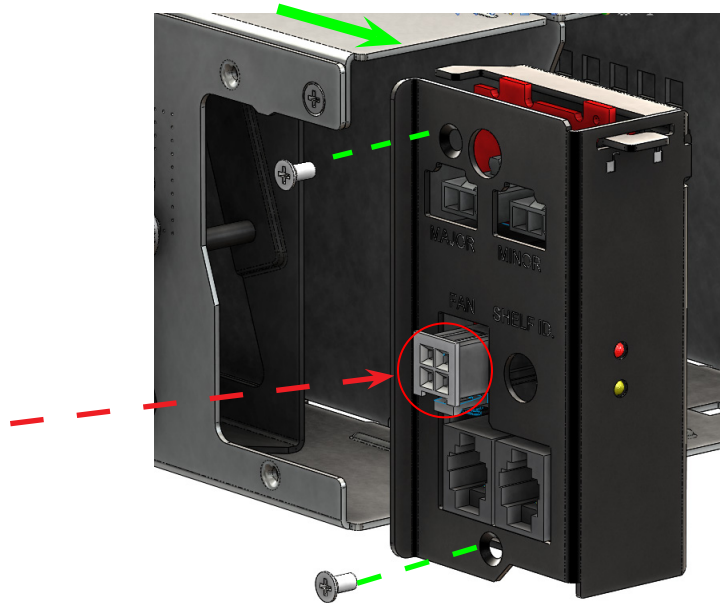

- Insert the new interface Kit 0380148-001 and reverse the instructions.
 - Make sure that the ribbon cable maintains some slack during the pin connection.

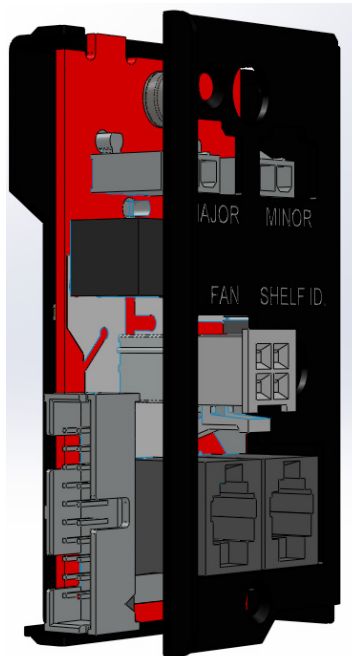

- Re-insert the controller (if applicable).

7.7 Spare Parts

Blanking plate kit (contains 2 plates)	0380070-001
Alarm relay replacement kit (19/23")	0380148-001 (includes PCB and bracket)
Fan tray connector (19/23")	8700590-001
Can Bus terminator (19/23")	5450228-001
Fan tray replacement assembly (19")	0300055-004
Fan tray replacement assembly (23")	0300090-004
Fan tray (6")	0300189-002
Input cable kit (6" shelf)	8700870-001

8. Warranty Statement and Service Information

8.1 Technical Support

In Canada and the USA, call toll free 1-888-462-7487.

Customers outside Canada and the USA, call +1-604-436-5547.

8.2 Warranty Statement

For full information details review Alpha's online Warranty Statement at www.alpha.ca/support.

8.3 Product Warranty

Alpha warrants that for a period of two (2) years from the date of shipment its products shall be free from defects under normal authorized use consistent with the product specifications and Alpha's instructions, the terms of the manual will take precedence.

The warranty provides for repairing, replacing or issuing credit (at Alpha's discretion) for any equipment manufactured by it and returned by the customer to the factory or other authorized location during the warranty period.

There are limitations to this warranty coverage. The warranty does not provide to the customer or other parties any remedies other than the above. It does not provide coverage for any loss of profits, loss of use, costs for removal or installation of defective equipment, damages or consequential damages based upon equipment failure during or after the warranty period. No other obligations are expressed or implied. Warranty also does not cover damage or equipment failure due to cause(s) external to the unit including, but not limited to, environmental conditions, water damage, power surges or any other external influence.

The customer is responsible for all shipping and handling charges. Where products are covered under warranty Alpha will pay the cost of shipping the repaired or replacement unit back to the customer.

8.4 Battery Warranty

Note that battery warranty terms and conditions vary by battery and by intended use. Contact your Alpha sales representative or the Technical Support team at the above number to understand your entitlements under Battery Warranty.

8.5 Warranty Claims

Any claim under this Limited Warranty must be made in writing to Alpha BEFORE sending material back. Alpha will provide Product return instructions upon approval of return request. A Service Repair Order (SRO) and / or Return Authorization (RA) number will be issued ensuring that your service needs are handled promptly and efficiently.

Claims must be made online at: www.alpha.ca.

8.6 Service Information

For a list of international service centers, refer to the Alpha website: www.alpha.ca

9. Acronyms and Definitions

AC	Alternating current
ANSI	American National Standards Institute
AWG	American Wire Gauge
BTU	British thermal unit
CAN	Controller area network
CEC	Canadian Electrical Code
CSA	Canadian Standards Association
CX	Cordex™ series; e.g., CXC for Cordex System Controller
DC	Direct current
EMC	Electromagnetic compatibility
EMI	Electromagnetic interference
ERM	Electromagnetic Compatibility and Radio Spectrum Matters
ESD	Electrostatic Discharge
FCC	Federal Communications Commission (for the USA)
GFI	Ground fault interrupt
IP	Internet Protocol
LED	Light emitting diode
LVD	Low voltage disconnect
MIL	One thousandth of an inch; used in expressing wire cross sectional area
MOV	Metal oxide varistor
MTBF	Mean time between failures
NC	Normally closed
NEC	National Electrical Code (for the USA)
NO	Normally open
OSP	Outside plant
OVP	Over voltage protection
RFT circuit	Remote feeding telecommunication circuit: A secondary circuit within the equipment, intended to supply or receive DC power via a telecommunication network at voltages exceeding the limits for TNV circuits, and on which overvoltages from telecommunication networks are possible.
RFT-V circuit	An RFT circuit, which is so designed and protected that under normal operating conditions and single fault conditions, the voltages are limited and the accessible area of contact is limited.
RU	Rack unit (1.75")
SELV	Safety Extra Low Voltage
TCP/IP	Transmission Control Protocol / Internet Protocol
THD	Total harmonic distortion
UL	Underwriters Laboratories

10. Certification

About CSA and NRTL

CSA (Canadian Standards Association also known as CSA International) was established in 1919 as an independent testing laboratory in Canada. CSA received its recognition as an NRTL (Nationally Recognized Testing Laboratory) in 1992 from OSHA (Occupational Safety and Health Administration) in the United States of America (Docket No. NRTL-2-92). This was expanded and renewed in 1997, 1999, and 2001. The specific notifications were posted on OSHA's official website as follows:



- Federal Register #: 59:40602 - 40609 [08/09/1994]
- Federal Register #: 64:60240 - 60241 [11/04/1999]
- Federal Register #: 66:35271 - 35278 [07/03/2001]

When these marks appear with the indicator “C and US” or “NRTL/C” it means that the product is certified for both the US and Canadian markets, to the applicable US and Canadian standards. (1)



Alpha rectifier and power system products, bearing the aforementioned CSA marks, are certified to CSA C22.2 No. 60950-1 (2nd Ed) and UL 60950-1 (2nd Ed). Alpha UPS products, bearing the aforementioned CSA marks, are certified to CSA C22.2 No. 107.3 and UL 1778.

As part of the reciprocal, US/Canada agreement regarding testing laboratories, the Standards Council of Canada (Canada's national accreditation body) granted Underwriters Laboratories (UL) authority to certify products for sale in Canada. (2)



Only Underwriters Laboratories may grant a licence for the use of this mark, which indicates compliance with both Canadian and US requirements. (3)

NRTLs capabilities

NRTLs are third party organizations recognized by OSHA, US Department of Labor, under the NRTL program.

The testing and certifications are based on product safety standards developed by US based standards developing organizations and are often issued by the American National Standards Institute (ANSI). (4)

The NRTL determines that a product meets the requirements of an appropriate consensus-based product safety standard either by successfully testing the product itself, or by verifying that a contract laboratory has done so, and the NRTL certifies that the product meets the requirements of the product safety standard. (4)

Governance of NRTL

The NRTL Program is both national and international in scope with foreign labs permitted.

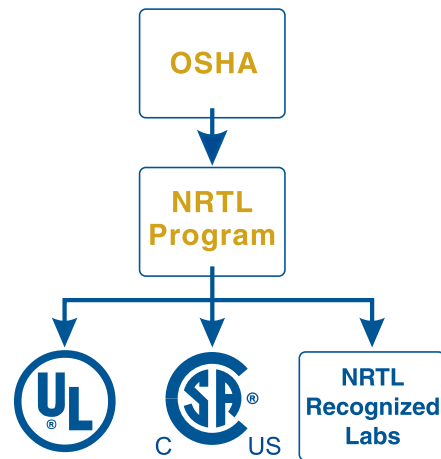

(1) www.csagroup.org

(2) www.scc.ca

(3) www.ulc.ca

(4) www.osha.gov

REVISIONS			
LTR	DESCRIPTION	DWN	DATE
C	Initial Outline & Customer Connection(s)	H.Wu	11/22/2013
CHK	Z.L		

OUTLINE AND CUSTOMER CONNECTION FOR 19IN LPS36 SHELF

DO NOT SCALE DRAWING

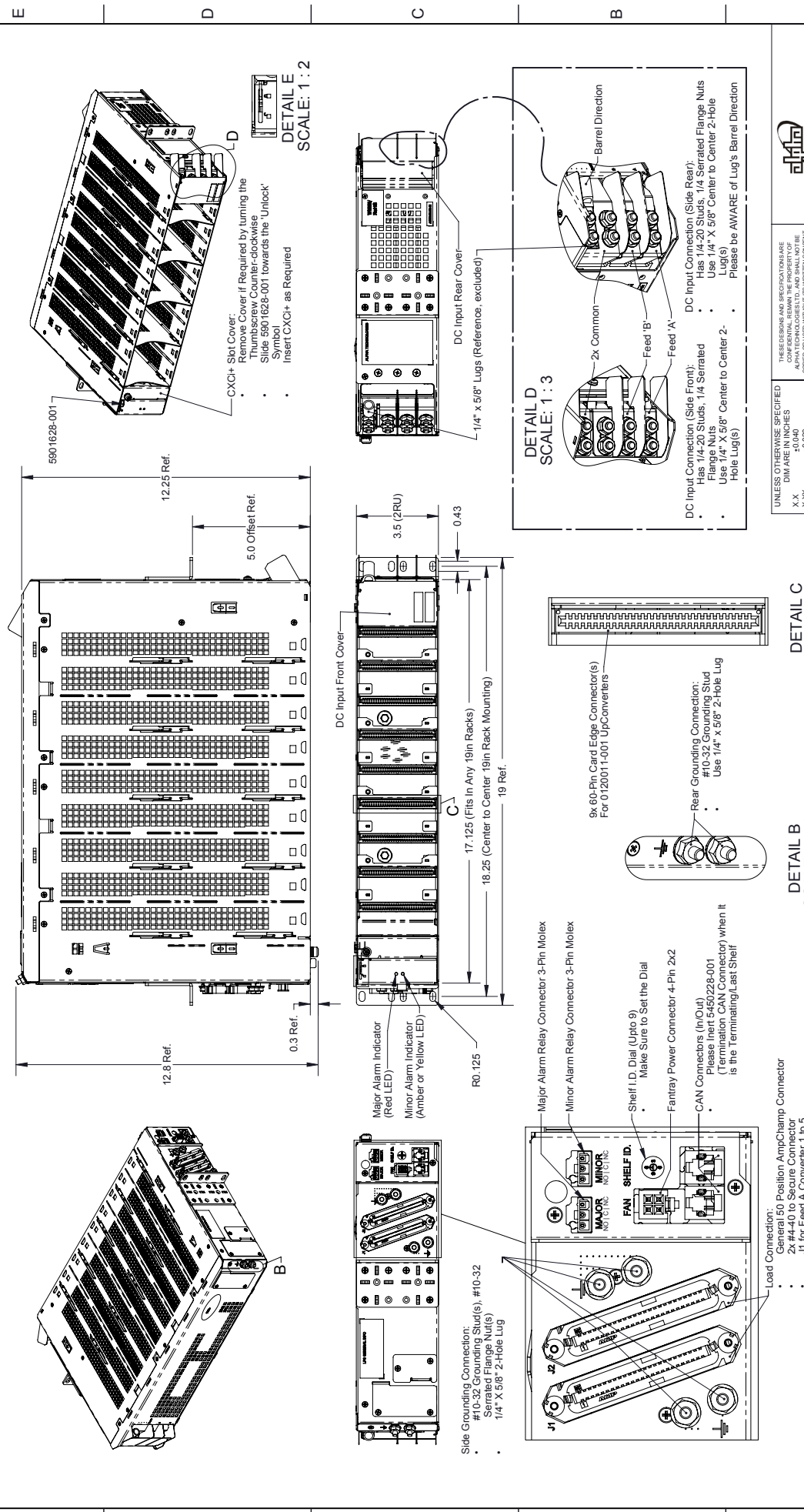

UNLESS OTHERWISE SPECIFIED			
DIM ARE IN INCHES	UNLESS OTHERWISE SPECIFIED	DATE	NOV-21-13
X.XX	±0.020	DRAWN	H.WU
X.XXX	±0.010	CHECKED	
ANGULAR	±1°	APPROVALS	
INTERPRETATION	SEE UG 1-9.4	DATE	
THIRD ANGLE PROJECTION		CHECKED	

ALPHA TECHNOLOGIES™			
THESE DESIGNS AND SPECIFICATIONS ARE CONFIDENTIAL. REMAIN THE PROPERTY OF ALPHA TECHNOLOGIES. NO REUSE, REPRODUCTION, COPIED OR USED WITHOUT ITS WRITTEN CONSENT.			
TITLE: Cust. Connection, Shelf Fantray, .Batfile, 19in, LPS36			
SIZE	DWG NO.	SCALE:	1:1
B	0300055-08		
REV		SHEET	1 OF 2
C			

NOTES UNLESS OTHERWISE SPECIFIED:

1. PRODUCT TO BE FABRICATED ACCORDING TO ATL PRODUCTION STANDARD 0700001

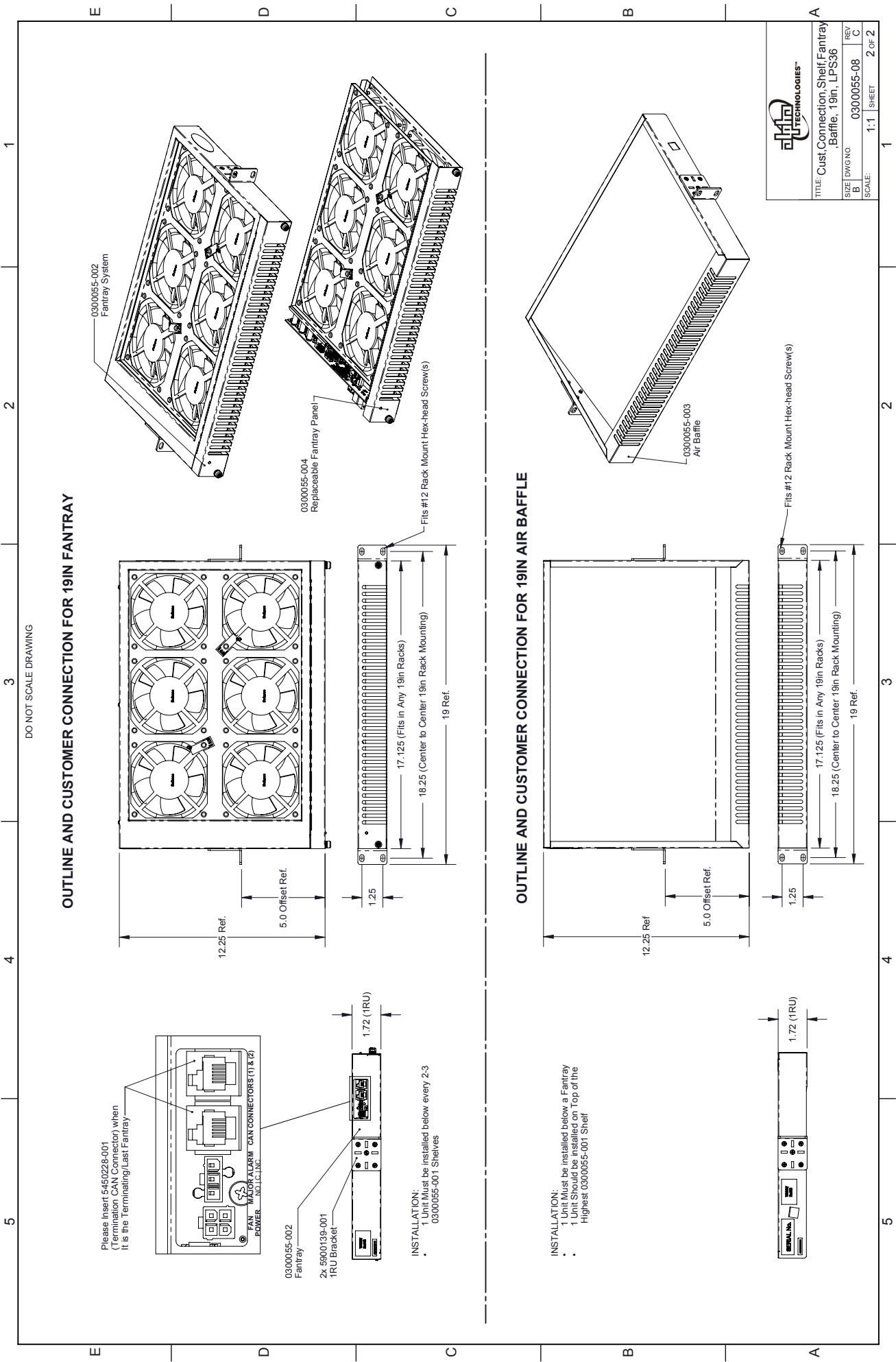

DO NOT SCALE DRAWING

OUTLINE AND CUSTOMER CONNECTION FOR 19IN FANTRAY

Please Insert 5450228-001 (Termination CAN Connector) when it is the Terminating/Last Fantray

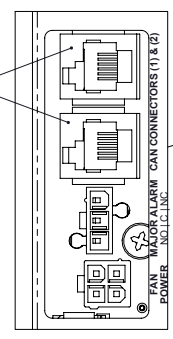

- 0300055-002 Fantray
- 2x 5900139-001 1RU Bracket

INSTALLATION:
 1 Unit Must be installed below every 2,3 0300055-001 Shelves

OUTLINE AND CUSTOMER CONNECTION FOR 19IN AIR BAFFLE

INSTALLATION:
 1 Unit Must be installed below a Fantray
 1 Unit Should be installed on Top of the Highest 0300055-001 Shelf

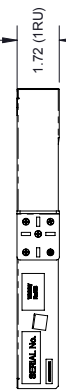

Fits #12 Rack Mount Hex-head Screw(s)

- 17.125 (Fits in Any 19in Racks)
- 18.25 (Center to Center 19in Rack Mounting)

19 Ref.

TITLE: Cust. Connection, Shelf Fantray, Air Baffle, 19in., LPS36	
SIZE	DWG NO.
B	0300055-08
C	
SCALE:	1:1 SHEET 2 OF 2

REVISIONS		1	
LTR	DESCRIPTION	DWN	DATE
C	Initial Outline & Customer Connection(s)	H.Wu	11/28/2013
Z.L			

DO NOT SCALE DRAWING

OUTLINE AND CUSTOMER CONNECTION FOR 23IN LPS36 SHELF

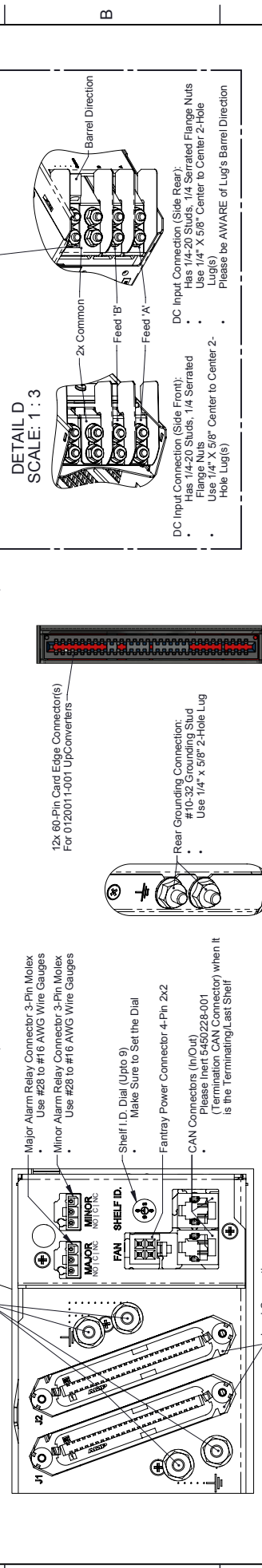
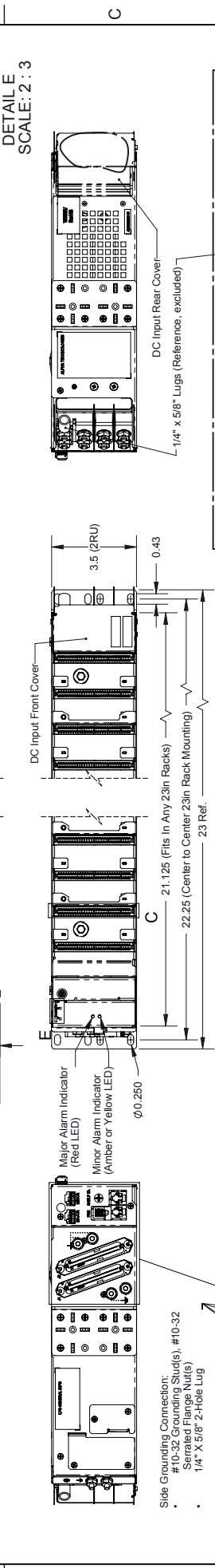
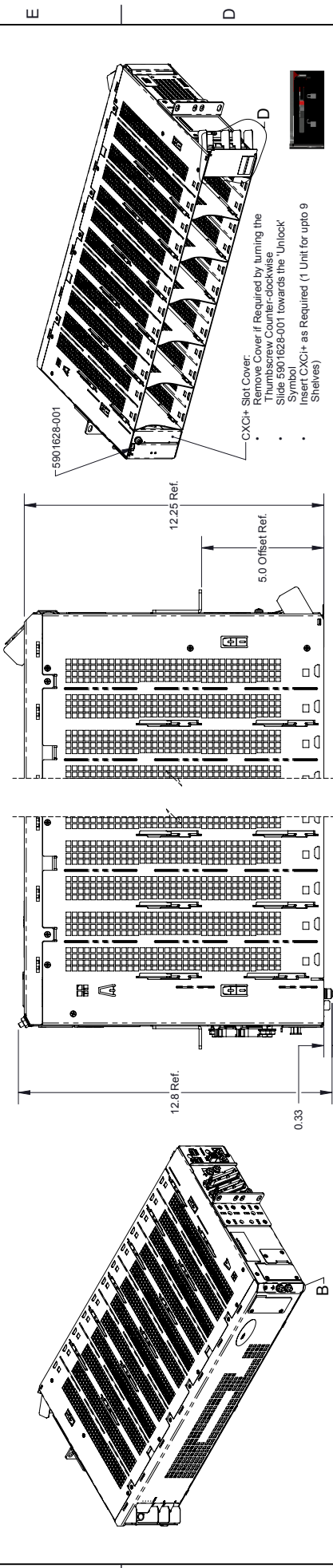

DETAIL A
SCALE: 1 : 1.5

DETAIL B
SCALE: 1 : 1.5

DETAIL C
SCALE: 1 : 1.5

DETAIL D
SCALE: 1 : 3

DETAIL E
SCALE: 2 : 3

UNLESS OTHERWISE SPECIFIED
DIM ARE IN INCHES
X.X
X.XX
X.XXX
ANGULAR
INTERPOLATED PER
ASME Y14.5M

THIRD ANGLE PROJECTION

© ALPHA TECHNOLOGIES LTD

SCALE: 1:1 SHEET 1 OF 2

REV C 030.0090-08 LPS36

TITLE: Cust. Connection, Shelf Fantray, .Batfile, 23in, LPS36

DATE NOV-26-13

H.WU

APPROVALS

DRAWN

CHECKED

MMW-DD-YY

CONFIDENTIAL - REMAIN THE PROPERTY OF ALPHA TECHNOLOGIES LTD. NO REPRODUCTION OR USE WITHOUT ITS WRITTEN CONSENT

THESE DESIGNS AND SPECIFICATIONS ARE

NOTES UNLESS OTHERWISE SPECIFIED:

- PRODUCT TO BE FABRICATED ACCORDING TO ATL PRODUCTION STANDARD 0700001

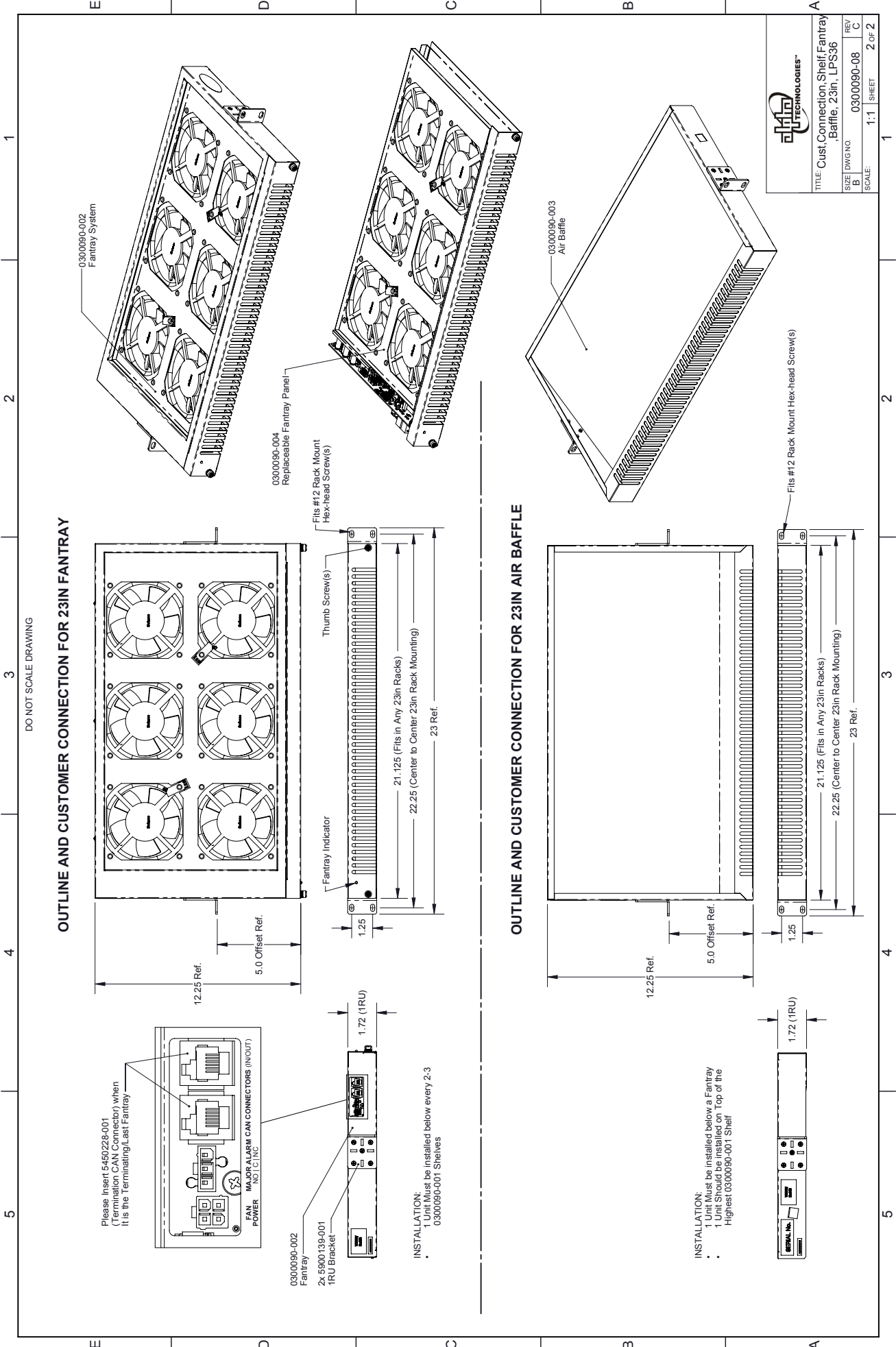

DO NOT SCALE DRAWING

OUTLINE AND CUSTOMER CONNECTION FOR 23IN FANTRAY

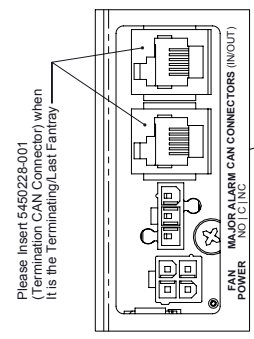

Please Insert 5450228-001 (Termination CAN Connector) when it is the Terminating/Last Fantray.

0300090-002 Fantray
2x 5900139-001 1RU Bracket

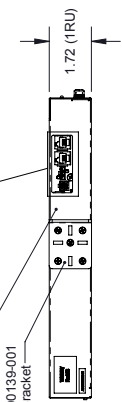

INSTALLATION:
Unit Must be installed below every 2-3 0300090-001 Shelves

OUTLINE AND CUSTOMER CONNECTION FOR 23IN AIR BAFFLE

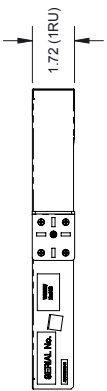
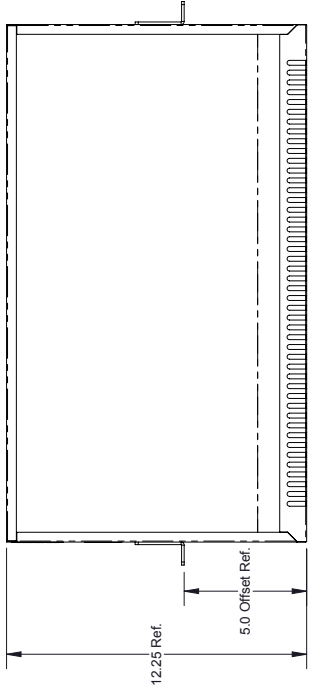

INSTALLATION:
1 Unit Must be installed below a Fantray
1 Unit Should be installed on Top of the Highest 0300090-001 Shelf

Fits #12 Rack Mount Hex-head Screw(s)

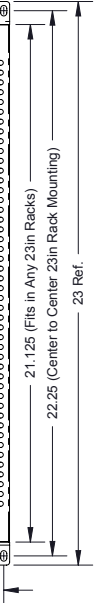

21.125 (fits in Any 23in Racks)
22.25 (Center to Center 23in Rack Mounting)
23 Ref.

1.72 (1RU)

TITLE: Cust. Connection, Shelf Fantray, Baffle, 23in, LPS36	
SIZE	DWG NO.
B	0300090-08
C	
SCALE:	1:1 SHEET 2 OF 2

REVISIONS			
LTR	DESCRIPTION	DWN	DATE
A	INITIAL RELEASE	KLAU	Apr-24-15
B	ADDED -004 CONFIG	KLAU	Dec-03-15

LTR	DESCRIPTION	DWN	DATE	CHK
A	INITIAL RELEASE	KLAU	Apr-24-15	ZL
B	ADDED -004 CONFIG	KLAU	Dec-03-15	ZL

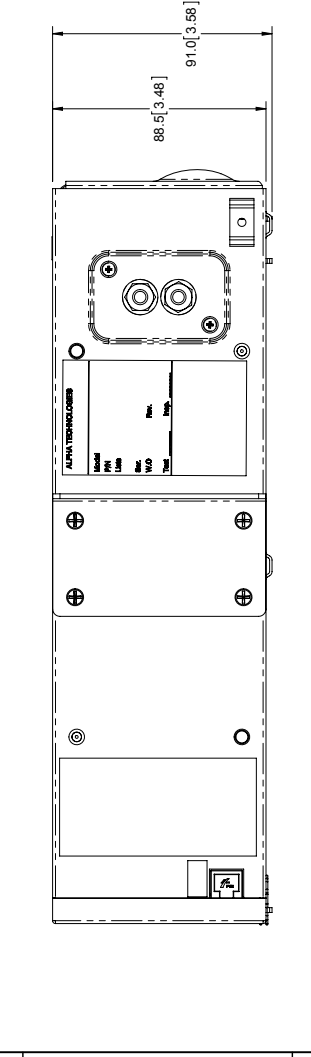
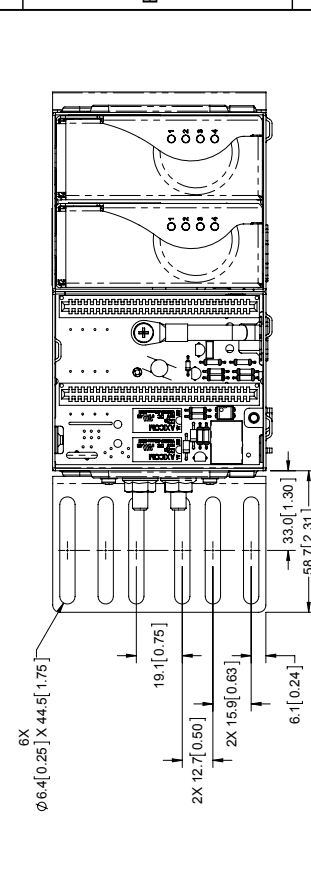
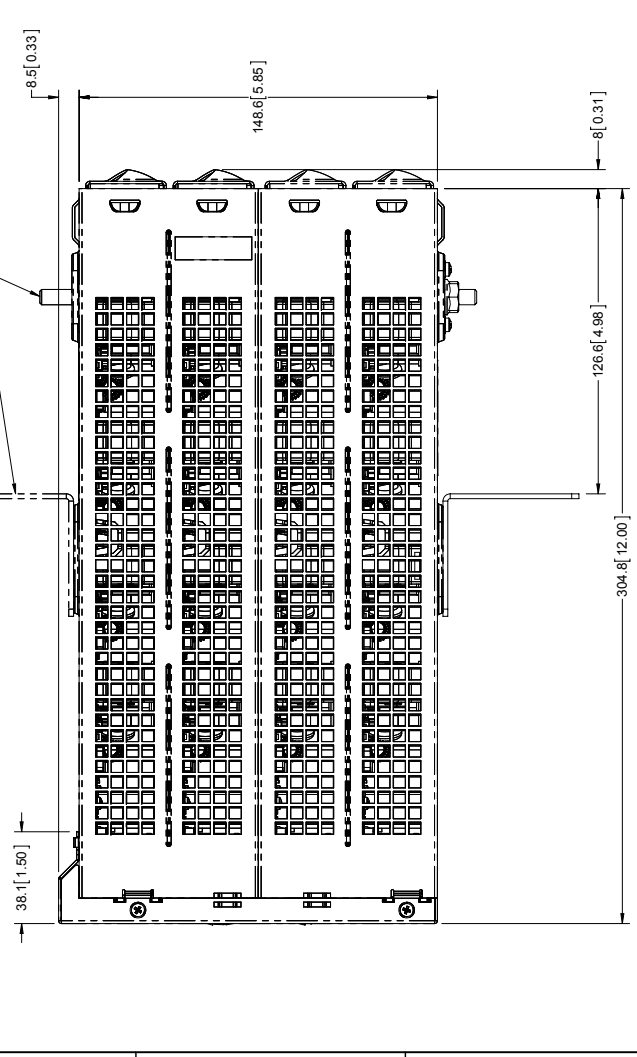
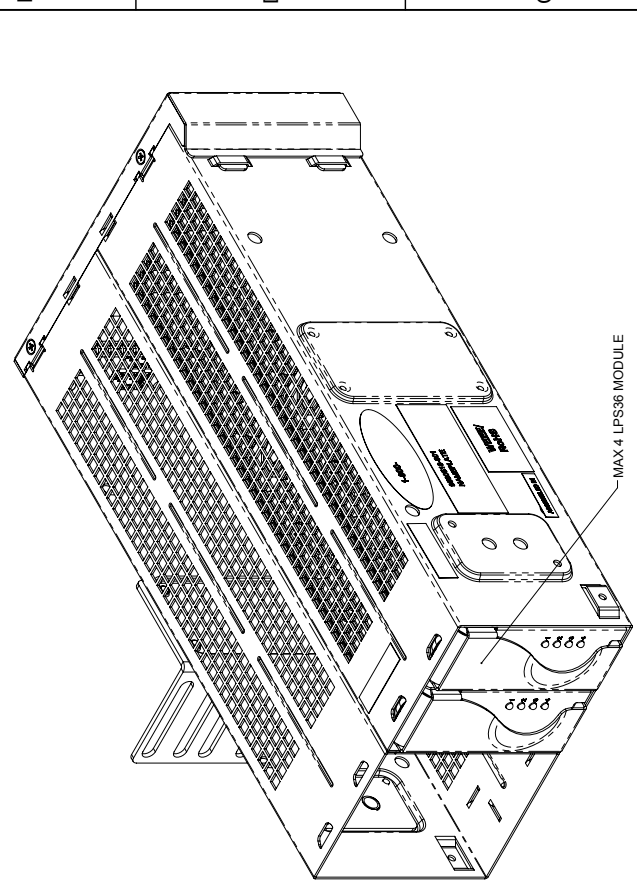

UNLESS OTHERWISE SPECIFIED DIM ARE IN MM

X.X 1.0
X.XX .50
ANGULAR: ±1°
INTERPRET DIM AND TOL PER ASME Y14.5M-1994

THIRD ANGLE PROJECTION

© ALPHA TECHNOLOGIES LTD

SCALE: 1:2 SHEET 1 OF 5

0300189-00X
6" LPS36 SHELF WITH MODULE INSTALLED
SEE SHIT Z FOR CABLE HARNESS DIMENSIONS

0300189-006
4 MOD

TITLE: OUTLINE, SHELF, LPS 36, 6"

APPROVALS: K. LAU Apr-30-15
DATE: Apr-30-15
DRAWN: Z. LANDER

THESE DESIGNS AND SPECIFICATIONS ARE CONFIDENTIAL. REMAIN THE PROPERTY OF ALPHA TECHNOLOGIES. NOT TO BE REPRODUCED OR USED WITHOUT ITS WRITTEN CONSENT.

1

2

3

4

5

DO NOT SCALE DRAWING

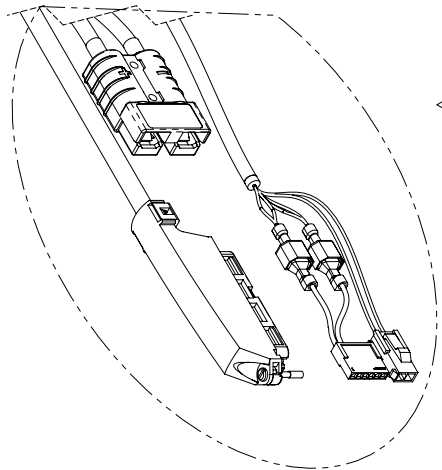
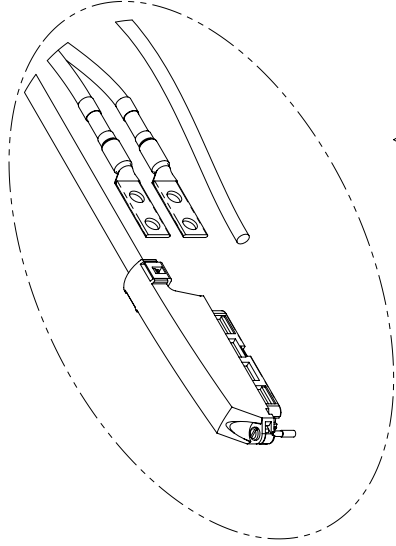
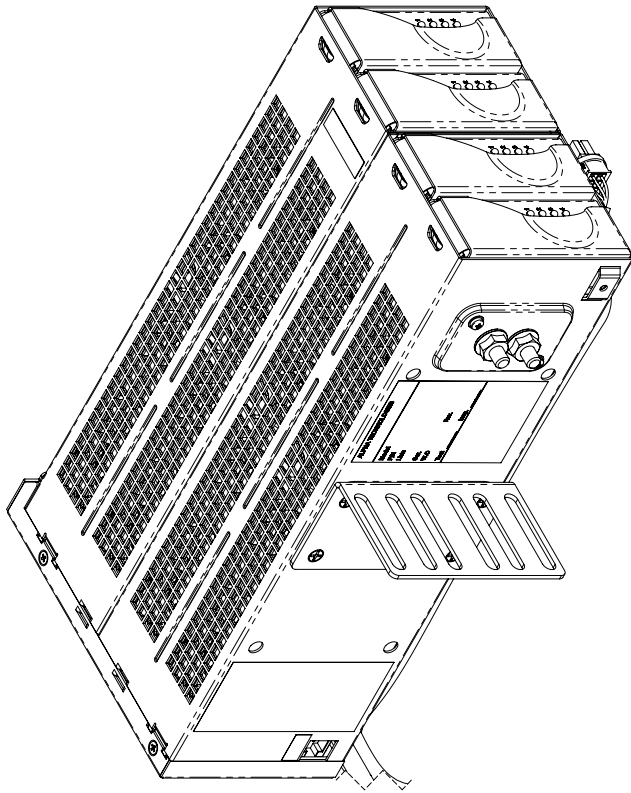

E

D

C

B

A

E

D

C

B

A



TITLE: OUTLINE, SHELF, LPS 36, 6"
4 MOD

SIZE	DWG NO.	REV
B	0300189-06	B
SCALE:	1:2	SHEET 2 OF 5

1

2

3

4

5

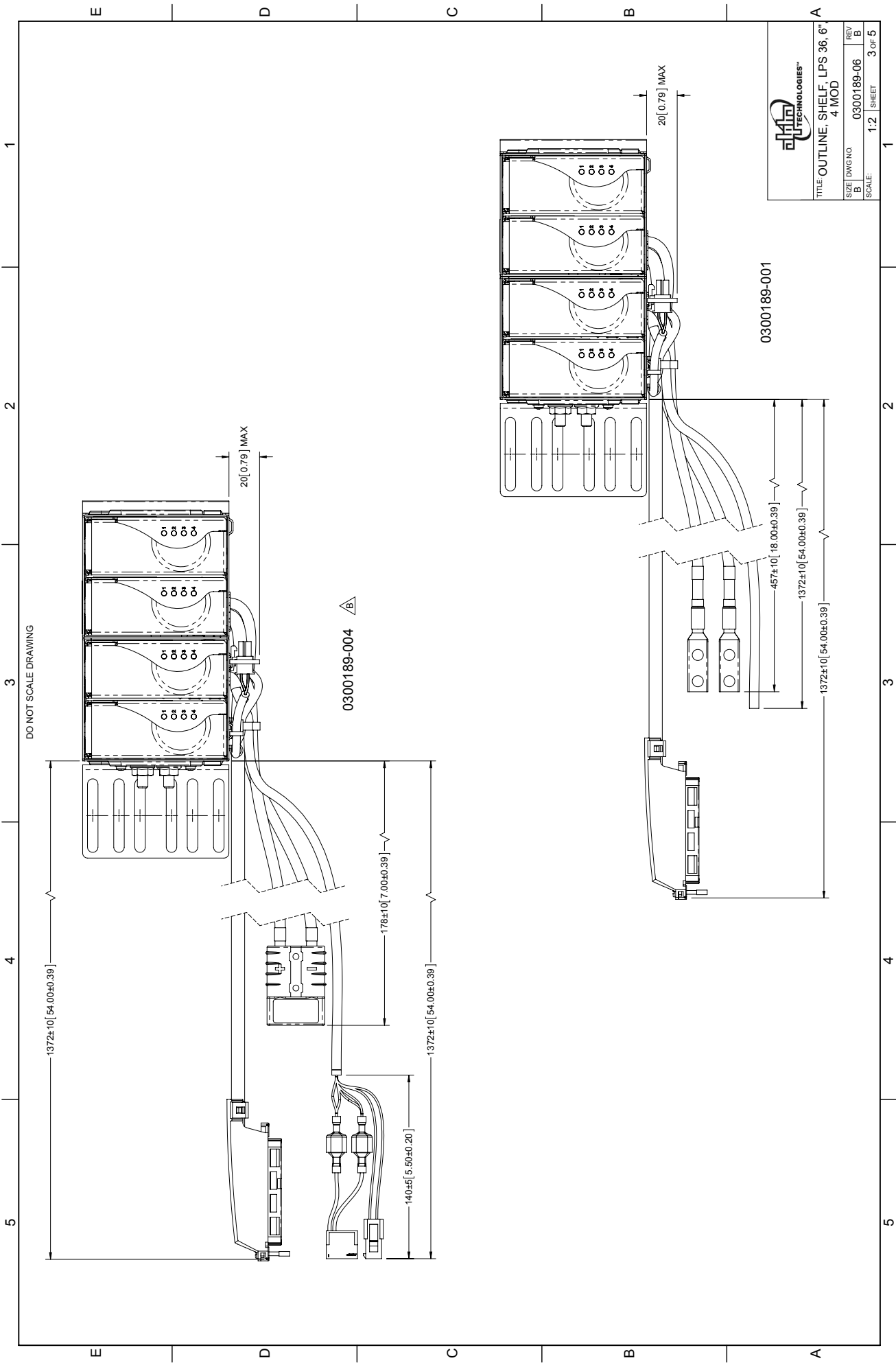

ALPION TECHNOLOGIES™

TITLE: OUTLINE, SHELF, LPS 36, 6"
4 MOD

SIZE	DWG NO.	REV
B	0300189-06	B
SCALE:	1:2	SHEET 3 OF 5

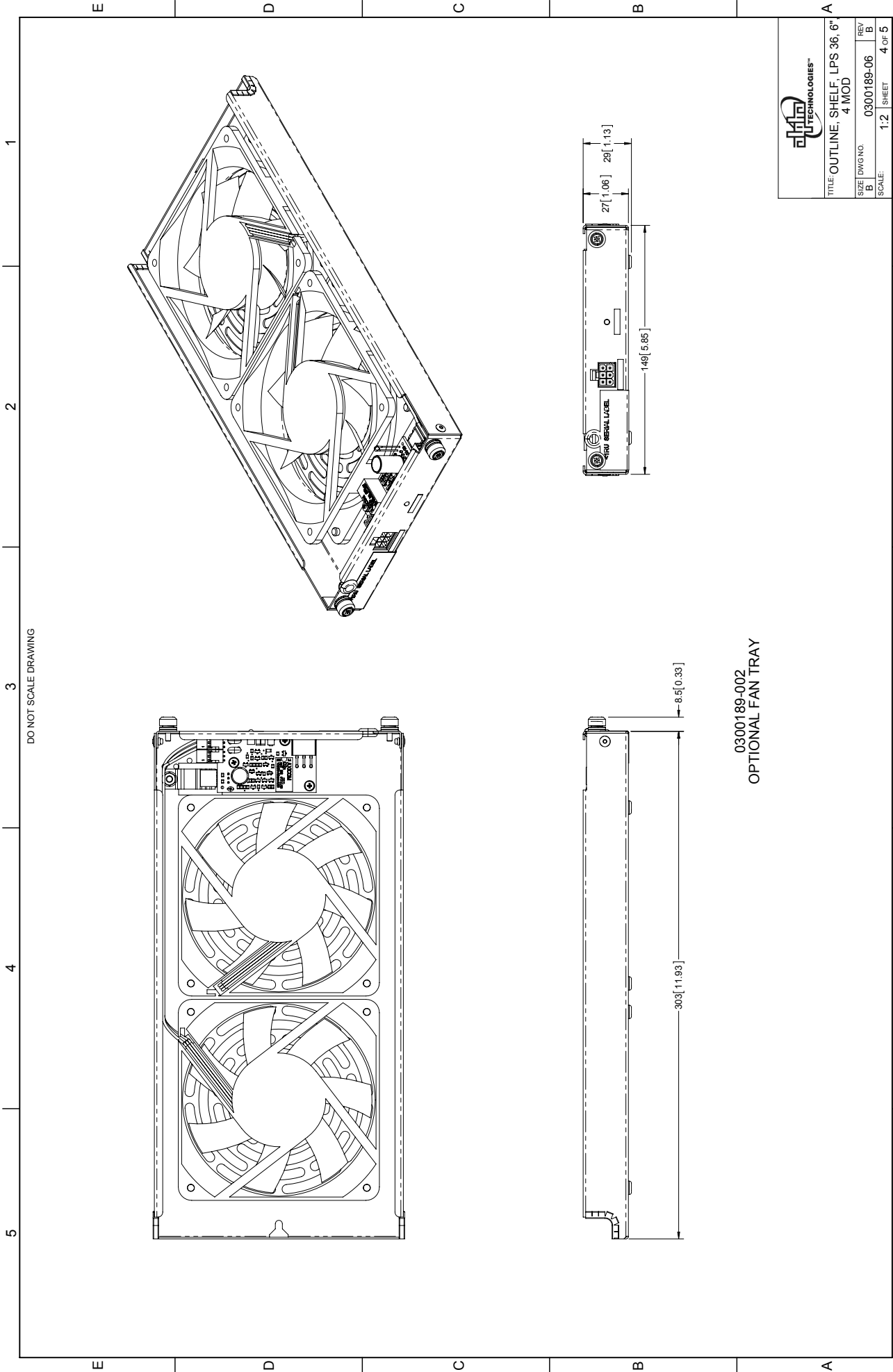

0300189-002
OPTIONAL FAN TRAY

ALPHA TECHNOLOGIES™

TITLE: OUTLINE, SHELF, LPS 36, 6"
4 MOD

SIZE	DWG NO.	REV
B	0300189-06	B
SCALE:	1:2	SHEET 4 OF 5

DO NOT SCALE DRAWING

REVISIONS		DESCRIPTION	DWN	DATE	CHK
A	INITIAL RELEASE		KLAU	May-29-15	GL
B	ADDED -04 CONFIGURATION		KLAU	Dec-03-15	JK

OUTPUT CONNECTIONS			CAN BUS		
PIN#	MODULE	CHANNEL	PIN #	SIGNAL	
1		CH1_-190V	1	GND	
2	1	CH2_-190V	2	CANH	
3		CH3_-190V	3	NC	
4		CH4_-190V	4	CANL	
5		CH1_-190V	5	NC	
6	2	CH2_-190V	6	NC	
7		CH3_-190V			
8		CH4_-190V			
9	1	CH1_-190V			
10	3	CH2_-190V			
11		CH3_-190V			
12		CH4_-190V			
13		CH1_-190V			
14	4	CH2_-190V			
15		CH3_-190V			
16		CH4_-190V			
17		NC			
18		NC			
19		NC			
20		NC			
21		NC			
22		NC			
23		NC			
24		NC			
25		NC			

ALARM CABLE CONNECTIONS	
WIRE COLOUR	ALARM SIGNAL
BROWN	FAN ALM NC
WHITE	FAN ALM COM
BLUE	FAN ALM NO
BLACK	MAJOR ALM NC
ORANGE	MAJOR ALM COM
RED	MAJOR ALM NO
VIOLET	MINOR ALM NC
YELLOW	MINOR ALM NO

OUTPUT POSITIONS, CHAMP-LOK TE 5229913-1 OR EQUIVALENT SEE OUTPUT CONNECTIONS TABLE	
PIN #	SIGNAL
1	GND
2	CANH
3	NC
4	CANL
5	NC
6	NC

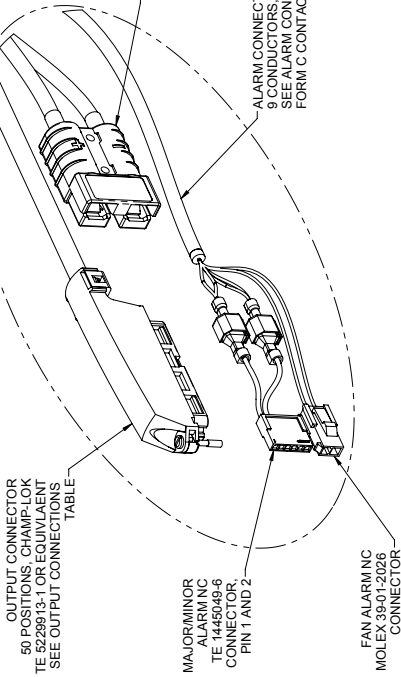
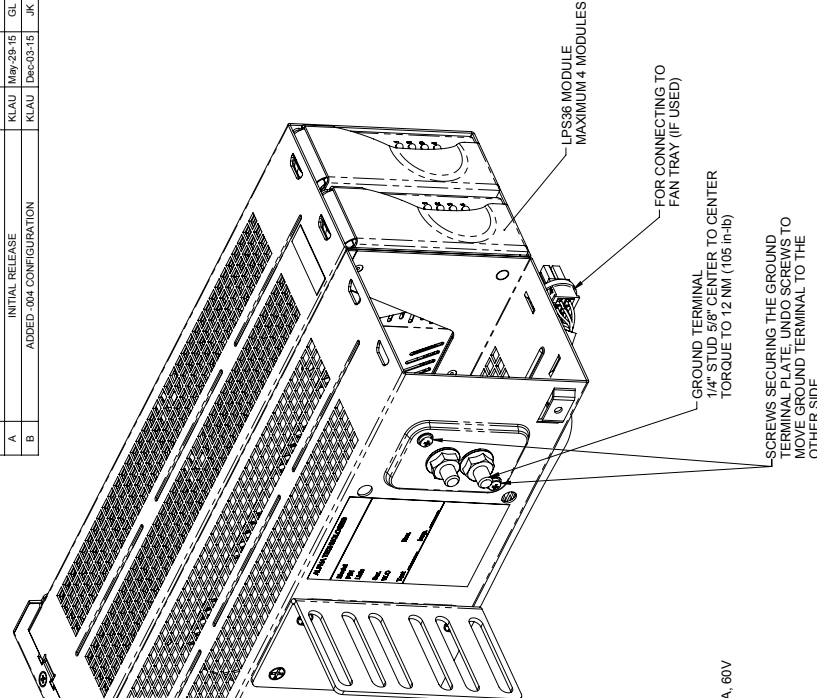
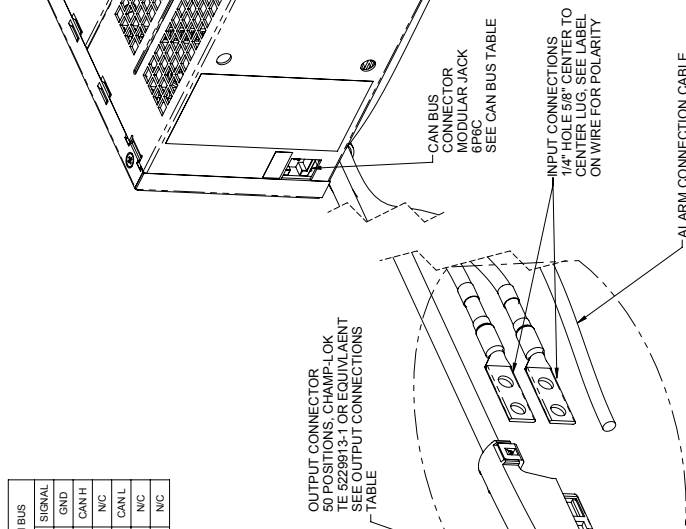

0300189-001

0300189-004

NOTES UNLESS OTHERWISE SPECIFIED:
 1. REFER TO NAMEPLATE FOR INPUT/OUTPUT VOLTAGE AND CURRENT RATINGS.

UNLESS OTHERWISE SPECIFIED DIM ARE IN MM		THESE DRAWINGS AND SPECIFICATIONS ARE CONFIDENTIAL-REMAIN THE PROPERTY OF ALPHA TECHNOLOGIES LTD. NO PART IS TO BE COPIED OR USED WITHOUT ITS WRITTEN CONSENT	
X.X	0.5	APPROVALS	DATE
X.XX	0.25	DRAWN	K.LAU
X.XXX	±1°	CHECKED	G. LUMANOG
INTERPRET DIM AND TOL PER ASME Y14.5M-1994		MAY-29-15	
THIRD ANGLE PROJECTION		© ALPHA TECHNOLOGIES LTD	
		TITLE: CUSTOMER CONNECTIONS	
		LPS 36 COMPACT SHELF	
SCALE: 1:2		SHEET 1 OF 1	
REV B		REV 0300189-08	

