



| an EnerSys® company

# EnVision™ Energy Router

1RU Remote Controllable Distribution Panel  
with Smart Switch Modules

**User Guide ID:** 0300311-J0

**Effective:** 11/2025



**Read this document carefully.**

Learn how to protect your equipment from damage and fully understand its functions.



**NOTICE**

The material contained in this document is for information only and is subject to change without notice.

# Contents

1. Safety.....	4
1.1 Safety symbols.....	4
1.2 General warnings and cautions.....	4
1.3 Electrical safety.....	5
2. Introduction.....	6
2.1 Document scope.....	6
2.2 Product overview.....	6
3. Specifications.....	7
3.1 EnVision™ Energy Router.....	7
4. Features.....	9
4.1 Ground connection.....	9
4.2 Feed connection.....	9
4.3 Load connections.....	10
4.4 Monitoring methods.....	10
4.5 Control method.....	11
5. Inspection.....	12
5.1 Packaging materials.....	12
5.2 Returns for service.....	12
5.3 Check for damage.....	12
5.4 General receipt of shipment.....	12
5.5 Miscellaneous small parts.....	12
6. Installation.....	13
6.1 Safety precautions.....	13
6.2 Tools required.....	13
6.3 Assembly and mounting.....	13
6.4 EnVision™ Smart Switch Module installation.....	14
7. Wiring.....	15
7.1 Installation notes.....	15
7.2 Chassis ground.....	17

- 7.3 DC output connections ..... 17
- 7.4 CAN serial ports ..... 18
- 8. Maintenance ..... 19
- 9. Troubleshooting ..... 20
  - 9.1 EnVision™ Smart Switch Module LED ..... 20







# 1. Safety

## Save these instructions

This document contains important safety instructions that must be followed during the installation, servicing, and maintenance of the product. Keep it in a safe place. Review the drawings and illustrations contained in this document before proceeding. If there are any questions regarding the safe installation or operation of this product, contact Alpha Technologies Ltd. or the nearest Alpha® power system representative.

### 1.1 Safety symbols

To reduce the risk of injury or death, and to ensure the continued safe operation of this product, the following symbols have been placed throughout this document. Where these symbols appear, use extra care and attention.

Symbol	Type	Description
	<b>WARNING</b>	<b>Risk of serious injury or death</b> Equipment in operation poses a potential electrical hazard which could result in serious injury or death to personnel. This hazard may continue even when power is disconnected.
	<b>CAUTION</b>	Cautions indicate the potential for injury to personnel.
	<b>CAUTION</b>	<b>Risk of burns</b> A device in operation can reach temperature levels which could cause burns.
	<b>ATTENTION</b>	The use of attention indicates specific regulatory or code requirements that may affect the placement of equipment or installation procedures. Follow the prescribed procedures to avoid equipment damage or service interruption.
	<b>GROUNDING</b>	This symbol indicates the location or terminal intended for the connection to protective earth. An enclosure that is not properly connected to protective earth presents an electrical hazard. Only a licensed electrician can connect AC power and protective earth to the enclosure.
	<b>NOTICE</b>	A notice provides additional information to help complete a specific task or procedure or general information about the product.

### 1.2 General warnings and cautions



#### **WARNING**

You must read and understand the following warnings before installing the enclosure and its components. Failure to do so could result in personal injury or death.

- Read and follow all instructions included in this document.
- Only trained personnel are qualified to install or replace this equipment and its components.
- Use proper lifting techniques whenever handling equipment, parts, or batteries.

 **WARNING**  
This equipment is not suitable for use in locations where children are likely to be present.

 **AVERTISSEMENT**  
Cet équipement ne convient pas pour une utilisation dans des lieux où des enfants sont susceptibles d'être présents.

### 1.3 Electrical safety

 **WARNING**  
Hazardous voltages are present at the input of power systems. The DC output from rectifiers, though not dangerous in voltage, has a high short-circuit current capacity that can cause severe burns and electrical arcing.

The DC output from converters is a potentially hazardous voltage. Do not touch the output connections when under power. Ensure that power has been removed from the outputs before working on them.

Before working with any live battery or power system, follow these precautions:

- Remove all metallic jewelry, such as watches, rings, metal rimmed glasses, or necklaces.
- Wear safety glasses with side shields at all times during the installation.
- Use insulated hand tools. Do not rest tools on top of batteries.

 **WARNING**  
Lethal voltages are present within the power system. Always assume that an electrical connection or conductor is energized. Check the circuit with a voltmeter with respect to the grounded portion of the enclosure (both AC and DC) before performing any installation or removal procedure.

- Do not work alone under hazardous conditions.
- A licensed electrician is required to install permanently wired equipment. Input voltages can range up to 480 VAC. Ensure the utility power is disconnected and locked out before performing any installation or removal procedure.
- Ensure that no liquids or wet clothes come into contact with internal components.
- Hazardous electrically live parts inside this unit are energized from the batteries even when the AC input power is disconnected.

 **WARNING**  
**High leakage current**

Earth connection is essential before connecting the supply.

 **WARNING**  
Intended to connect to a positive grounded system only.

Not intended to connect to floating or negative grounded systems.

## 2. Introduction

---

### 2.1 Document scope

This document covers the features, options, installation, and startup of the EnVision™ energy router 1RU remote controllable distribution panel. Images contained in this document are for illustrative purposes only and may not exactly match your installation. To assist with installation, refer to the drawings at the end of this document. This document covers the features and installation of the EnVision™ energy router distribution panel.

### 2.2 Product overview

The EnVision™ energy router distribution panel with the user installed EnVision™ smart switch modules has been designed to optimize space and efficiency. It offers unparalleled performance for powering and controlling essential infrastructure with precision and effectiveness.

This compact, 1RU solution provides more than just bus level voltage and current readings, individual module level output voltage, and current readings, but it also has controls to toggle each of the output remotely or manually, and protection to the load during an overcurrent condition.

The EnVision™ energy router distribution panel seamlessly distributes current to multiple device totaling up to 480 amps and at temperatures up to 149°F (65°C).

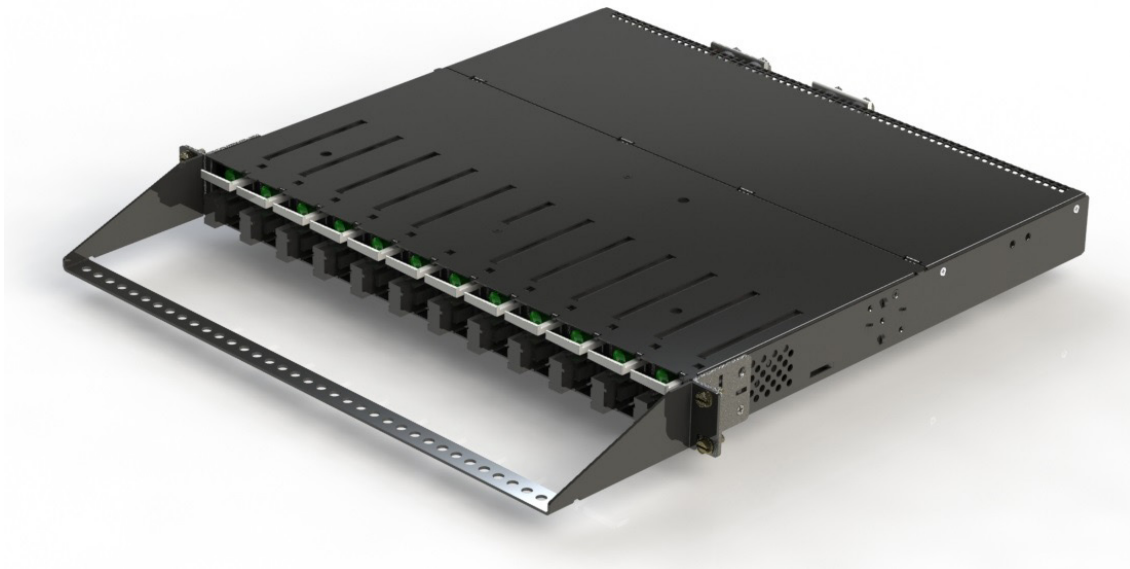

Figure 1: EnVision™ energy router distribution panel

## 3. Specifications

### 3.1 EnVision™ Energy Router

Table A: EnVision™ energy router specifications

<b>Electrical</b>	
<b>Source voltage</b>	–38 to –60 VDC
<b>Shelf input current capacity</b>	480 A
<b>EnVision™ Smart Switch Module capacity</b>	40 A continuous/45 A peak output per module
<b>Features</b>	
<b>LED</b>	Bicolor status LED switch
<b>Adjustments and controls</b>	Remote on/off
	Trip current
	Shut down timer
	Time schedule control
<b>Protection</b>	Overcurrent (trip)
	Short circuit
	Local user lock
	High voltage shutdown
	Low voltage shutdown
	Overtemperature shutdown
<b>Mechanical - Module</b>	
<b>Dimensions H x W x D</b>	1.6 x 1.3 x 9.8 in. (41 x 33 x 249 mm)
<b>Net Weight</b>	0.5 lb (0.2 kg)
<b>Output connector</b>	Molex® Mini-Fit for up to 8 AWG (10 mm <sup>2</sup> ) cable
	Front access output connectors
<b>Cooling<sup>1</sup></b>	Fan cooled
<b>Mechanical - Shelf</b>	
<b>Dimensions H x W x D</b>	1.7 x 17.1 x 16.3 in. (44 x 434.3 x 414 mm)
<b>Net Weight</b>	10 lb (4.5 kg)
<b>Modules per shelf</b>	Up to 12
<b>Mounting</b>	Flush mount
	6-pin offset center mount
<b>CAN communication</b>	RJ12 center
<b>Environmental</b>	
<b>Operating temperature</b>	–40 to 149°F (–40 to 65°C)
<b>Storage temperature</b>	–40 to 185°F (–40 to 85°C)
<b>Relative humidity</b>	5 to 95% non-condensing
<b>Elevation</b>	Up to 9,842 ft (3,000 m)

Regulatory compliance	
<b>Safety</b>	CAN/CSA-C22.2 No. 62368-1:19
	UL 62368-1 3 <sup>rd</sup> Edition
<b>EMC</b>	2014/30/EU EMC Directive
	FCC CFR 47 PART 15/B – Class A
	CAN ICES-003(A)/NMB-003(A)
	ETSI 300 386 v1.6.1
	ETSI 300 386 v2.1.1
	EN 55032:2015+A11:2020
	EN 61000-6-2:2019
	EN 61000-6-4:2017/A1:2011
	EN 55035:2017+A11:2020
<p><b>Note:</b> This equipment has been tested and found to comply with the limits for a Class B digital device, pursuant to part 15 of the FCC Rules. These limits are designed to provide reasonable protection against harmful interference in a residential installation. This equipment generates, uses and can radiate radio frequency energy and, if not installed and used in accordance with the instructions, may cause harmful interference to radio communications. However, there is no guarantee that interference will not occur in a particular installation. If this equipment does cause harmful interference to radio or television reception, which can be determined by turning the equipment off and on, the user is encouraged to try to correct the interference by one or more of the following measures:</p> <ul style="list-style-type: none"> <li>• Reorient or relocate the receiving antenna.</li> <li>• Increase the separation between the equipment and receiver.</li> <li>• Connect the equipment into an outlet on a circuit different from that to which the receiver is connected.</li> <li>• Consult the dealer or an experienced radio/TV technician for help.</li> </ul>	
<p><sup>1</sup> The fan turns on at 113°F (45°C) and then will turn off when the temperature drops below 104°F (40°C).</p> <p><sup>2</sup> Future development.</p>	

# 4. Features

## 4.1 Ground connection

Located at the right side rear (looking at it from the front), the distribution panel has a lug landing for connection to earth ground for use with ¼ inch bolts on ⅝ inch centers.

The distribution panel ground can either be connected to the frame in which the distribution panel is mounted if the frame is grounded, or they can be connected directly to the ground bar in a remote location. A minimum 6 AWG (16 mm<sup>2</sup>) wire is recommended.

Follow all local codes and company safety protocols for the ground connections. This information should be used as a guide only.

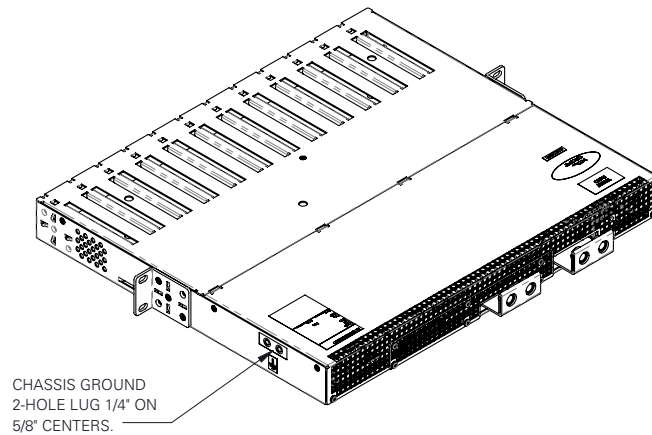

Figure 2: Distribution ground connection

## 4.2 Feed connection

DC output wire must be UL approved XHHW or RHH/RHW (for Canadian users, RW90 Type). Control and sense wires must be UL approved Style 1015 (for Canadian users, TEW type).

The common output leg of the distribution panel must be connected to ground, typically at the battery return bus.



### CAUTION

Leave cables or busbars disconnected at the battery and verify the output polarity using a voltmeter. Make battery connections only after all other wiring is completed.

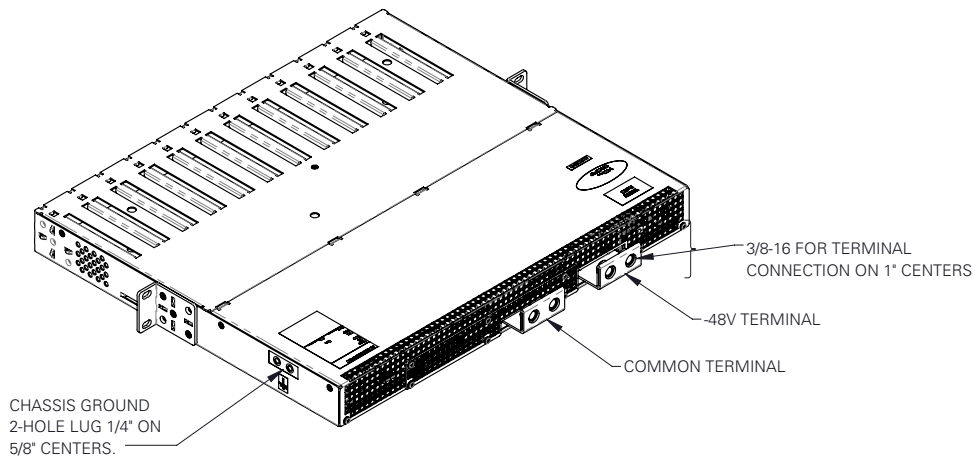

Figure 3: Feed connections



**CAUTION**

The load connection being added should not have a breaker installed or be live when the cables are installed.

### 4.3 Load connections

The system is a single bus and has a total of 12 position for EnVision™ smart switch modules and each modules with its own output connections. All output connections are front accessible utilizing a quick connect/disconnect male Molex® Mini-Fit connector. Available 6 foot (182 cm) 8 AWG (10 mm<sup>2</sup>) black and red cable assemblies can be used to connect each output to a load and an optional lacing bar can be attached at the front to create an orderly wiring look.

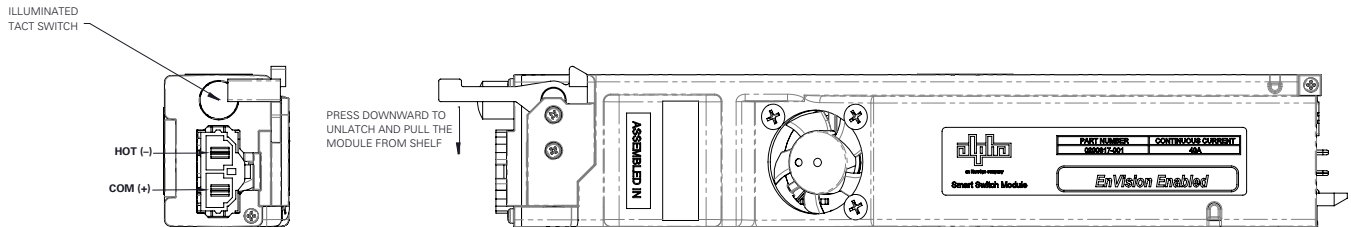

Figure 4: EnVision™ smart switch module front and side view

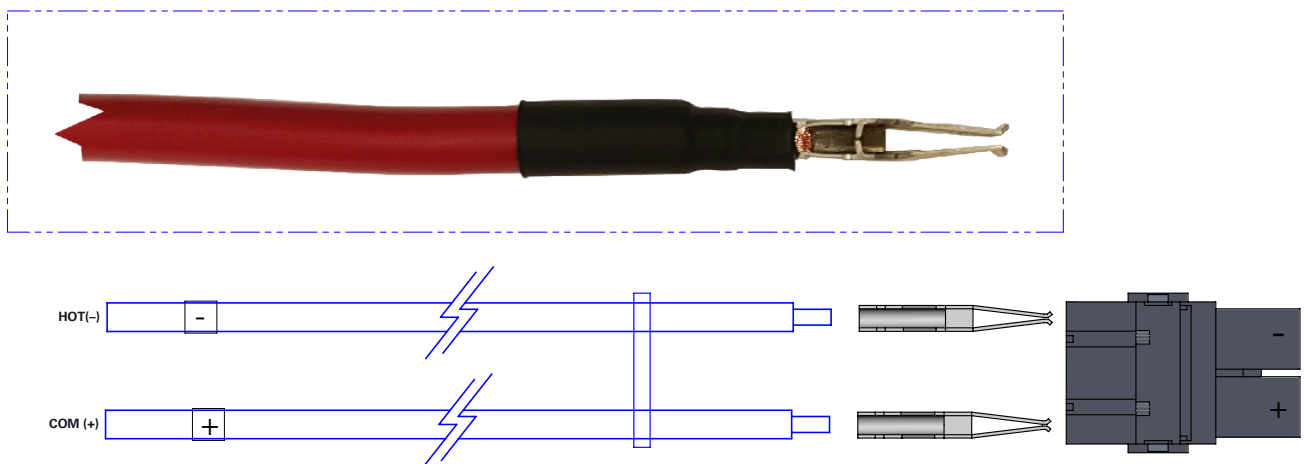

Figure 5: Load cable

### 4.4 Monitoring methods

The distribution panel provides both a standard CAN connector to connect with a EnVision™ Elite controller or Cordex® HP system controller.

The module provides a bicolor LED switch for both a on and off control toggle as well as output indication; green for ON and red or flashing red for OFF.

### 4.4.1 EnVision™ Smart Switch Module labelling

Modules are numbered starting from one near the side panel and going up to 12. The labels for the bus A breakers are indicated by black letters, labels for bus B are indicated by white letters. The breaker position index label is a thin strip over the breakers and is visible from the front, while the breaker assignment label is located on the top of the front panel and has additional space for describing the use of the breaker. This label is visible from the front when the door is open, as well as from the top when the door is closed.

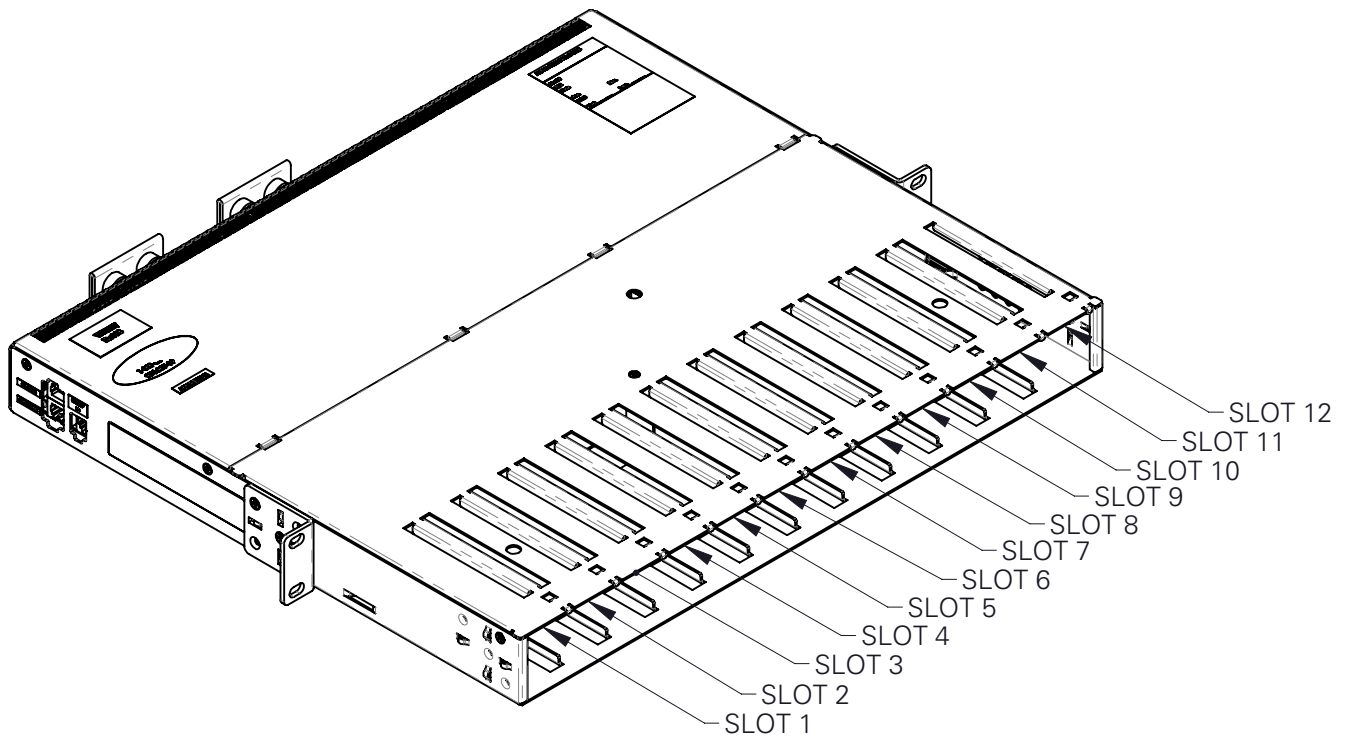

Figure 6: Smart switch position labelling

### 4.4.2 Network connection and remote communication

The distribution panel can be set up, monitored, and tested using the EnVision™ Elite controller or Cordex® HP system controller via an Ethernet 10/100 BASE-T serial data connection. The communication protocol supports a web interface. A CAN bus is used to transmit all alarm and control functions between the controller and distribution panel.

## 4.5 Control method

The output of the smart switch modules has an adjustable current limit and can be adjusted via the controller.

## 5. Inspection

---

### 5.1 Packaging materials

Alpha Technologies Ltd. is committed to providing products and services that meet our customers' needs and expectations in a sustainable manner, while complying with all relevant regulatory requirements. As such we strive to follow quality and environmental objectives from product supply and development through to the packaging for our products.

Almost all packaging material is from sustainable resources and or is recyclable.

### 5.2 Returns for service



#### NOTICE

**Alpha Technologies Ltd. is not responsible for damage caused by improper packaging of returned products.**

Save the original shipping container. If the product needs to be returned for service, it should be packaged in its original shipping container. If the original container is unavailable, make sure that the product is packed with at least three inches of shock-absorbing material to prevent shipping damage.

### 5.3 Check for damage

Before unpacking the product, note any damage to the shipping container. Unpack the product and inspect the exterior for damage. If any damage is observed, contact the carrier immediately. Continue the inspection for any internal damage. In the unlikely event of internal damage, inform the carrier and contact us for advice on the impact of any damage.

### 5.4 General receipt of shipment

The inventory included with your shipment depends on the options you have ordered. The options are clearly marked on the shipping container labels and bill of materials.

### 5.5 Miscellaneous small parts

Review the packing slip and bill of materials to determine the part number of the configuration kits included with your system. Review the bill of materials to verify that all the small parts are included. Contact us if you have any questions before you proceed.

## 6. Installation

---

The following procedure is written for qualified personnel to install this product in a clean and dry environment.

### 6.1 Safety precautions

Refer to the [Safety](#) section before beginning this installation.

### 6.2 Tools required

Various insulated tools are essential for the installation. Use this list as a guide:

- Various crimping tools and dies to match lugs used in installation
- Digital voltmeter equipped with test leads
- Cable cutters
- Torque wrench: ¼ inch drive, 0 to 150 in-lb (0 to 17 Nm)
- Torque wrench: ⅜ inch drive, 0 to 100 ft-lb (0 to 135 Nm)
- Insulating canvases as required
- Various insulated hand tools including:
  - Combination wrenches
  - Ratchet and socket set
  - Various screwdrivers
  - Electricians knife
- Cutters and wire strippers 2.5 to 0.34 mm<sup>2</sup> (14 to 22 AWG)
- Cutters and wire strippers 10 to 4 mm<sup>2</sup> (8 to 25 AWG)

### 6.3 Assembly and mounting

The distribution panel must be mounted in a clean and dry environment. Sufficient free space must be provided at the front and rear of the distribution panel in order to meet the cooling requirements and to allow easy access to the distribution panel components.

Attach the distribution panel to the customer-provided relay rack using mounting screws and star washers. This will ensure an electrical bond between the system chassis and relay rack.

The distribution panel can be mounted into a 19-inch rack in a center or flush mount position. The unit is shipped with the mounting brackets in the front mounted position. Move them to the center position as desired and attach 19-inch to 23-inch rack adapters when installed in a 23-inch rack.

## 6.4 EnVision™ Smart Switch Module installation

1. Orient the module so that the handle is at the top.
2. Align the module to the guide slots.
3. Carefully push the module into position.
4. Ensure that the module is fully inserted so that the locking mechanism is engaged.

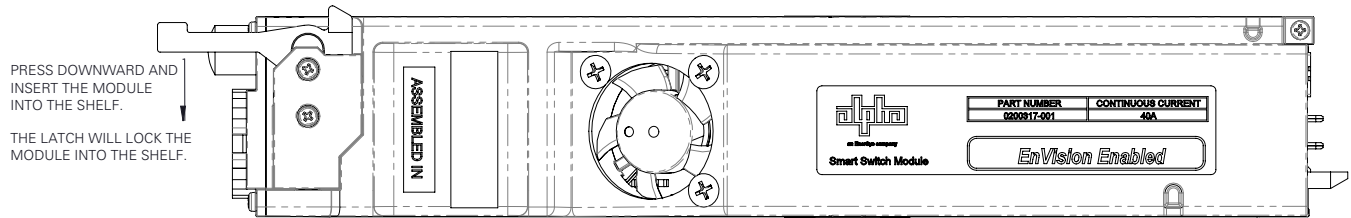

Figure 7: EnVision™ smart switch module installation

## 7. Wiring

This chapter provides cabling details and notes on cable sizing for DC applications with respect to the product.



### WARNING

Ensure that the power is switched off by switching off rectifiers and removing battery line fuses, turn off battery breakers before attempting work on the wiring. Use a voltmeter to verify the absence of a voltage. Clearly mark the correct polarity of the battery leads before starting work on DC connections.

### 7.1 Installation notes

Refer to the Installation section for safety precautions and tools required.

#### 7.1.1 Calculating input and output wire size requirements

Although DC power wiring and cabling in telecommunication applications tend to exceed electrical code requirements, mostly due to the voltage drop requirements, all applicable electrical codes take precedence over the guidelines and procedures in the present chapter, wherever applicable.

Wire size is calculated by first determining the appropriate maximum voltage drop requirement. Use the following formula to calculate the circular mil area (CMA) wire size requirement. Determine the size and number of conductors required to satisfy the CMA requirement.

$$\text{CMA} = (\text{A} \times \text{LF} \times \text{K}) / \text{AVD}$$

**A = Ultimate drain in amps.**

**LF = Conductor loop feet.**

**K = 11.1 constant factor for commercial (TW type) copper wire.**

**AVD = Allowable voltage drop.**

Check again that the ampacity rating of the cable meets the requirement for the installation application. Consult local electrical codes (for example, National Electrical Code® and Canadian Electrical Code) for guidelines. If required, increase the size of the cable to meet the code.

Refer to [Table B](#) for cable size equivalents.

Table B: Cable size equivalents (AWG to Metric)

Cable size	Circular mils	Square millimeters	Equivalent metric cable
20 AWG	1020	0.519	1
18 AWG	1624	0.8232	1
16 AWG	2583	1.309	1.5
14 AWG	4107	2.081	2.5
12 AWG	6530	3.309	4
10 AWG	10380	5.261	6
8 AWG	16510	8.368	10
6 AWG	26250	13.30	16
4 AWG	41740	21.15	25
2 AWG	66370	33.63	35
0 AWG (or 1/0)	105600	53.48	50 or 70
00 AWG (or 2/0)	133100	67.42	70
0000 AWG (or 4/0)	211600	107.2	120
313 MCM (or kcmil)	313600	159	150 or 185

Table B: Cable size equivalents (AWG to Metric)

<b>Cable size</b>	<b>Circular mils</b>	<b>Square millimeters</b>	<b>Equivalent metric cable</b>
350 MCM (or kcmil)	350000	177.36	185
373 MCM (or kcmil)	373700	189	185 or 240
500 MCM (or kcmil)	500000	253.36	300
535 MCM (or kcmil)	535300	271	300
750 MCM (or kcmil)	750000	380.00	400
777 MCM (or kcmil)	777700	394	400

## 7.1.2 Required torque values

The following table lists the recommended torque values for connection to the power system with the following hardware:

- Clear hole connections (nut and bolt)
- PEM studs
- PEM threaded inserts
- Thread formed connections (in copper busbar)

Grade 5 rated hardware is required for these torque values.

Table C: Recommended torque values

<b>Size</b>	<b>Torque value</b>
¼ inch	8.8 ft-lb (11.93 Nm)
⅜ inch	32.5 ft-lb (44.06 Nm)
½ inch	73 ft-lb (98.97 Nm)

## 7.2 Chassis ground

The distribution panel frame must be connected to the main ground bus (MGB) or frame ground bus (FGB) for safety reasons and to meet standard Telco grounding requirements. This acts as a system reference and a low impedance ground path for surges, transients and noise. The FGB or MGB should have a direct low impedance path to the building grounding system.

The cable from the distribution panel to the MGB should be sized to provide sufficient ampacity to clear the largest fuse or breaker on the distribution panel, excluding the battery protection fuse or circuit breaker. This is the minimum requirement; other factors including length of cable and special grounding requirements of the load should also be factored in. The insulated cable should be equipped with two-hole crimp type lugs and should not have any tight bends or kinks.

Use the landings found on the side close to the rear if the shelf to connect the chassis ground of the distribution panel to the building MGB. Recommended wire size is a minimum of 6 AWG (16 mm<sup>2</sup>) insulated cable.

This should be used as a guide, follow local codes and company safety protocols for the ground connections.

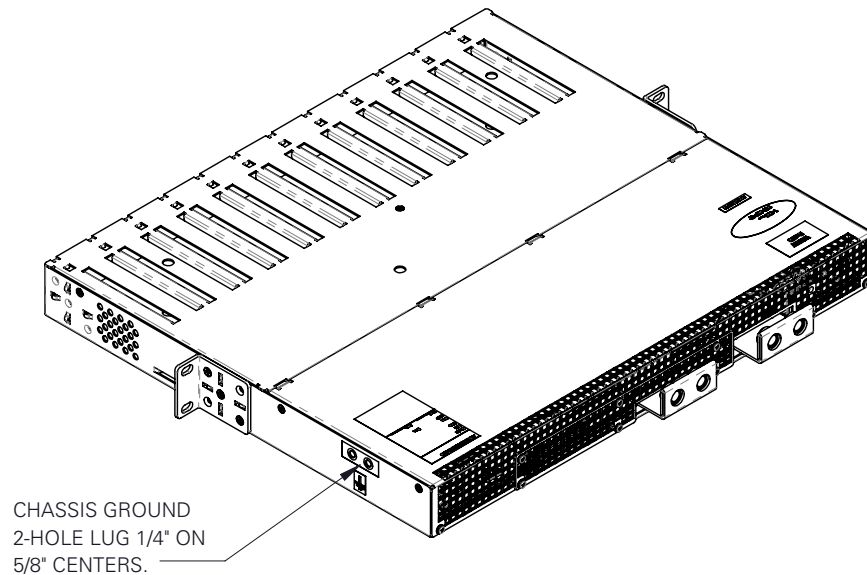

Figure 8: Chassis ground connection

## 7.3 DC output connections



### WARNING

Leave the cables or busbars disconnected at the load and verify the output polarity using a voltmeter. Make the connections only after this verification.

Output connections are located at the front of each module. They are Molex® Mini-Fit type and can handle up to 8 AWG (10 mm<sup>2</sup>).

Factory configured cables are available

### 7.3.1 DC input connection



### WARNING

Ensure that the correct polarity is used for all cable terminations.

The distribution panel is rated for a maximum 480 A per bus and the input connections are sized to accept up to a 750 MCM (400 mm<sup>2</sup>) cable per bus. All cables should be routed carefully and secured to the ladder rack or frame so that there is limited stress on the distribution panel connections.

## 7.4 CAN serial ports

The CAN serial ports are located on the side of the device and are clearly labelled. CAN serial ports are modular jacks with offset latches that are used to communicate with the rectifier modules and other CAN enabled equipment (nodes) on the same system. For more detailed information on CAN, refer to the reference section in the controller software manual.

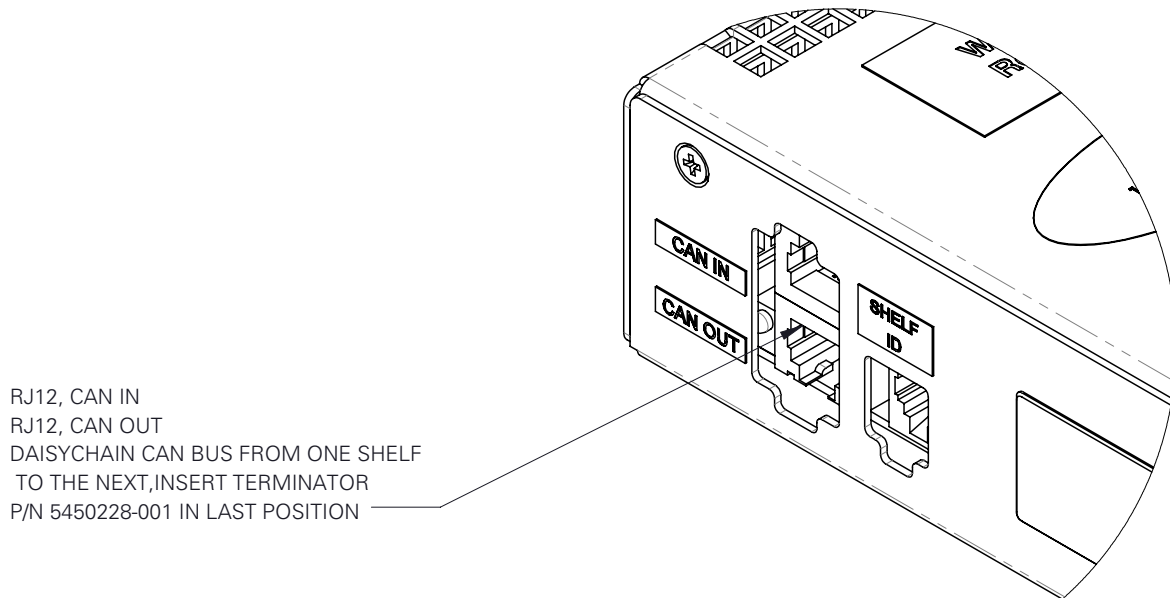

Figure 9: CAN (RJ12) connections

### 7.4.1 CAN termination

A CAN termination jumper is required at the last node of a CAN network. See the controller software manual for system configuration.

## 8. Maintenance

Although very little maintenance is required with EnVision™ distribution panel, routine checks and adjustments are recommended to ensure optimum system performance. Qualified service personnel should do the repairs. The following table lists a few maintenance procedures for this system. These procedures should be performed at least once a year.

Consult support or sales for all replacement parts.



### WARNING

Use extreme care when working inside the unit while the system is energized. Do not make contact with live components or parts.



### ATTENTION

Circuit cards, including semiconductor devices, can be damaged by static electricity. Always wear a grounded wrist strap when handling or installing circuit cards.



### ATTENTION

Ensure redundant modules or batteries are used to eliminate the threat of service interruptions while performing maintenance on the system's alarms and control settings.

Table D: Sample maintenance log

Procedure	Date completed
Inspect all panel connections. Re-torque if necessary.	
Verify alarm and control settings.	
Verify alarm relay operation.	
Clean ventilation openings of the switch modules and panel.	

## 9. Troubleshooting

The distribution panel and modules are designed for simple installation and reliable, trouble-free operation.

In most cases the modules will recover from minor alarms and faults automatically. However under certain conditions the modules may need remote control. And under very rare cases the module may need a manual reset (unplug and reinsert the module). In the unlikely event of a module failure, it may need replacement.

A shelf can accommodate up to 12 modules depending on the model. The EnVision™ smart switch module has a single bicolor LED status indicator that provides information about the module.

When the shelf system is used in conjunction with a system controller, detailed system information and status can be easily obtained. Additional information can be obtained via the web interface using the Ethernet port.

The following table provides a quick reference of the status LED and the corresponding states.

### 9.1 EnVision™ Smart Switch Module LED

Table E: EnVision™ smart switch module LED states

LED name	Color	State	Meaning
Bicolor status LED	Green	Off	Indicates no power to the module.
		Solid	Indicates the output channel is on.
		Flashing	N/A
	Red	Off	Indicates no power to the module.
		Solid	Indicates one of the following states: <ul style="list-style-type: none"> <li>Output is OFF due to hardware fault</li> <li>Output is OFF due to overcurrent</li> <li>Output is OFF due to short circuit</li> <li>Output is OFF due to overtemperature</li> <li>Output is OFF due to firmware upgrade</li> </ul>
		Flashing	Indicates one of the following states: <ul style="list-style-type: none"> <li>Output is OFF due to local user lock</li> <li>Output is OFF due to remote OFF request</li> </ul>

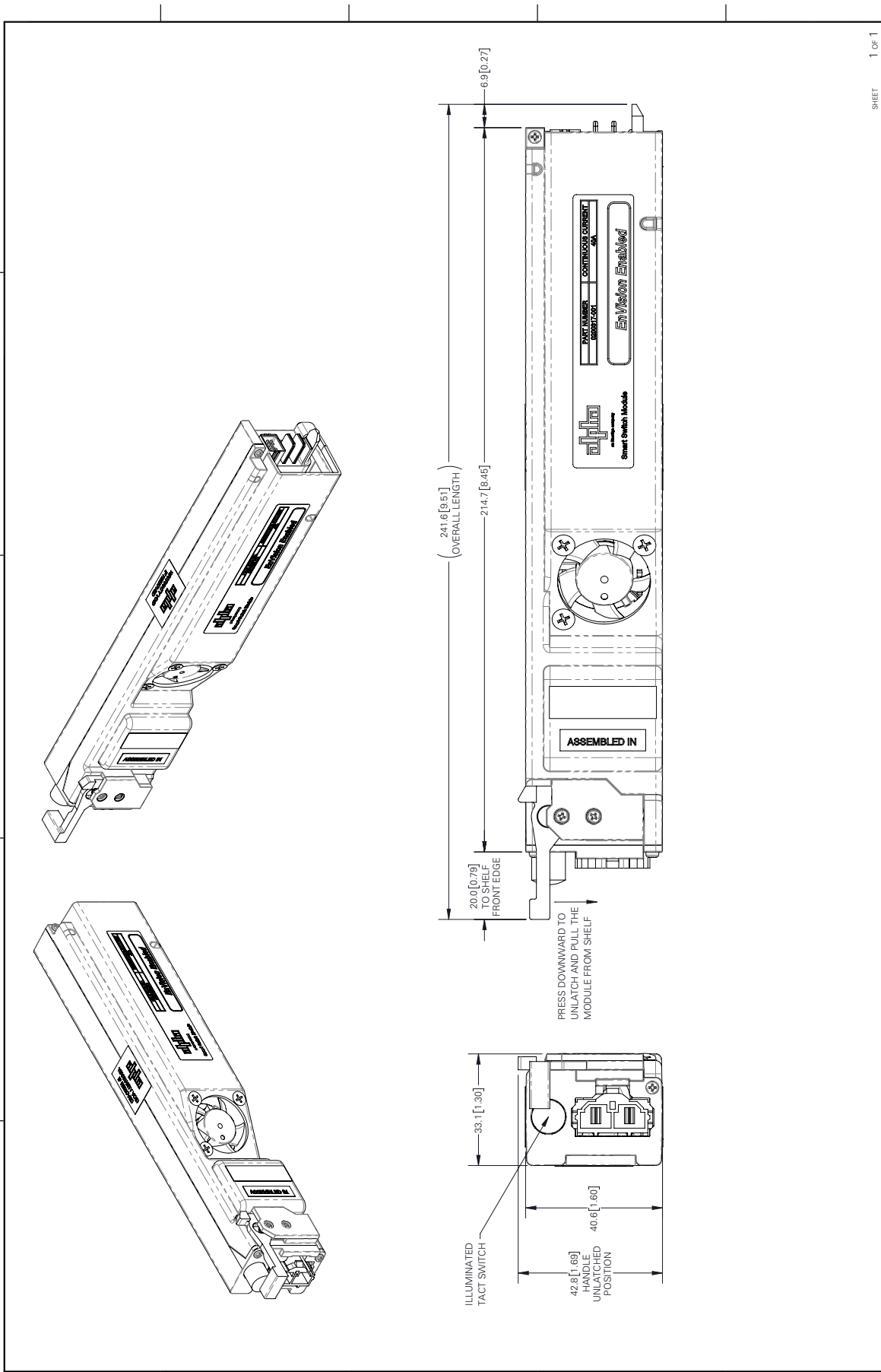

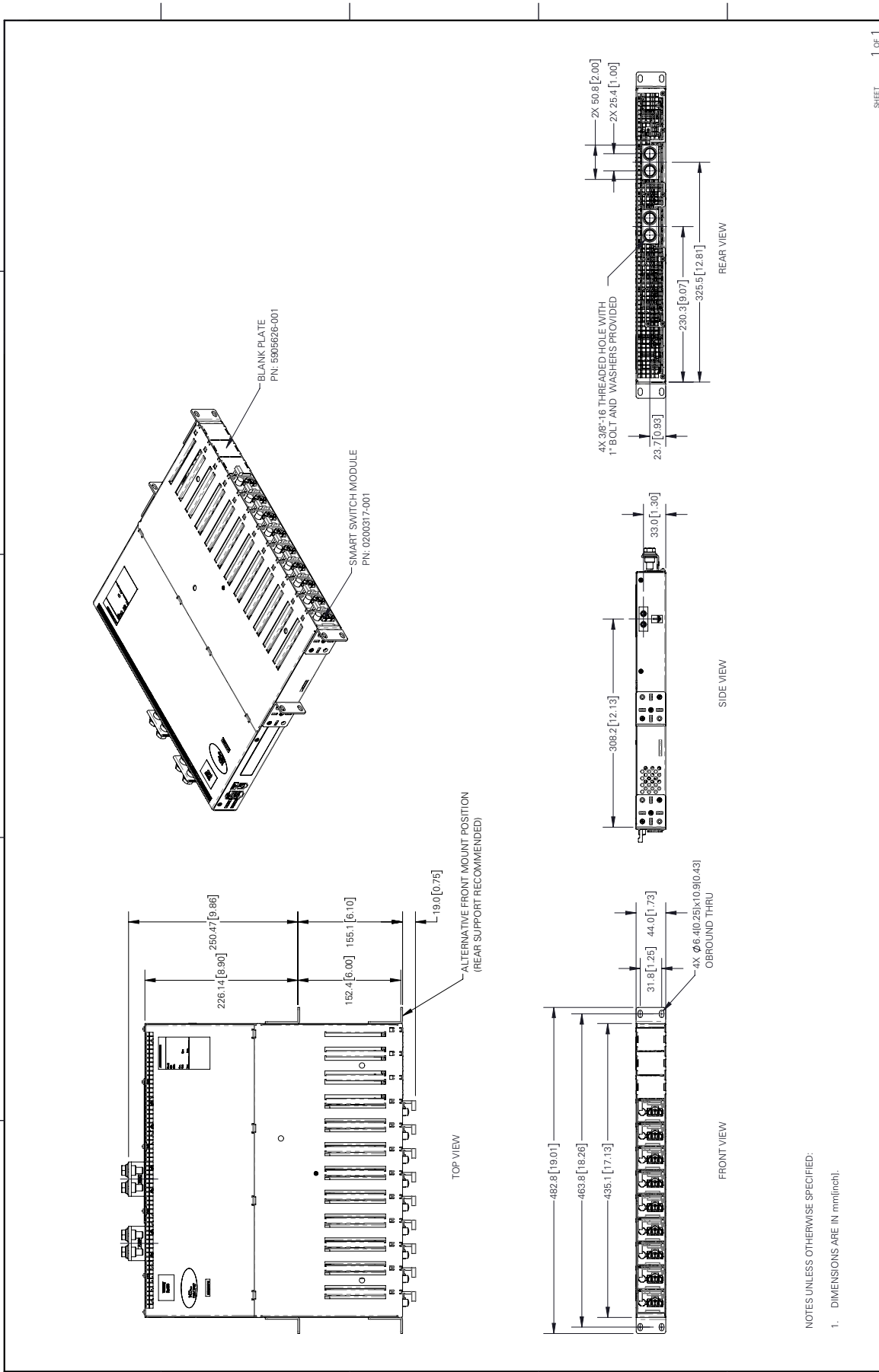

1 OF 1  
SHEET

NOTES UNLESS OTHERWISE SPECIFIED:  
1. DIMENSIONS ARE IN mm[inch].

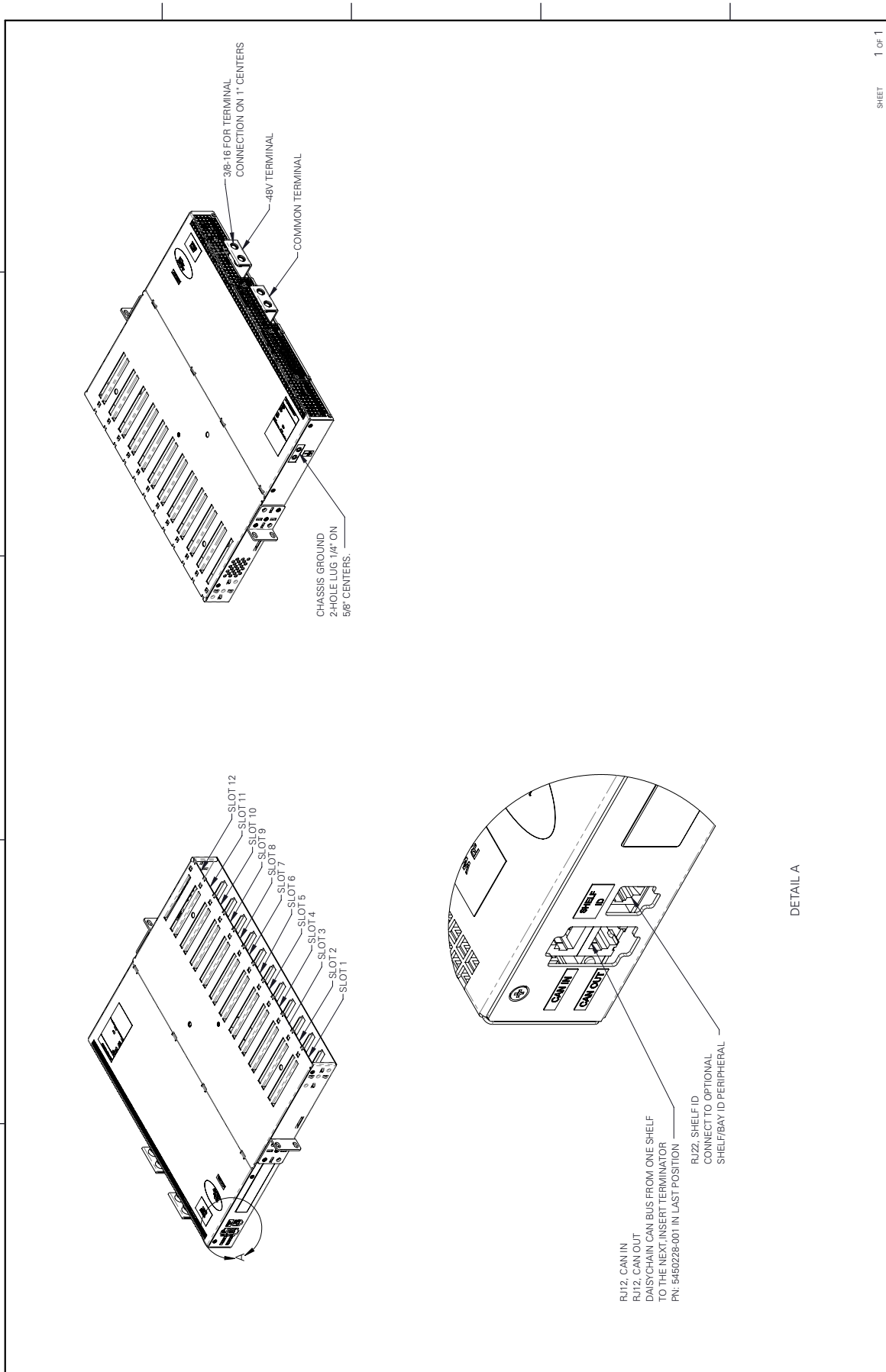



Alpha Technologies Ltd. | 7700 Riverfront Gate, Burnaby, BC V5J 5M4 Canada  
Toll Free North America: +1 800-667-8743 | Outside North America +1 604-436-5547 | Technical Support +1 888-462-7487

For more information visit our website at: [www.enersys.com](http://www.enersys.com)

© 2025 Alpha Technologies Ltd., an EnerSys company. All Rights Reserved. Trademarks and logos are the property of EnerSys and its affiliates except for ANSI®, CSA®, IEC®, IEEE®, NEC®, National Electrical Code®, Molex®, UL®, and Underwriters Laboratories®, which are not the property of EnerSys. Subject to revisions without prior notice. E. & O.E.